



# RODIX, Inc.

Toll Free (800) 562-1868, Fax (815) 316-4701  
 E-mail us today at [custserve@rodix.com](mailto:custserve@rodix.com)  
[www.rodix.com](http://www.rodix.com)

## Application Note: Linear Inline Feeders, Standard Inline 12" Long Part Numbers 007-000-0136 (120V) and 007-000-0143 (240V)

### Specifications:

<b>Part Number (120V)</b>	007-000-0136
<b>Electrical Power (120V)</b>	120 VAC, 50/60 Hz, 0.75 Amps
<b>Part Number (240V)</b>	007-000-0143
<b>Electrical Power (240V)</b>	240 VAC, 50/60 Hz, 0.4 Amps
<b>Unit Weight</b>	18 lbs.
<b>Max Track Length</b>	48 inches maximum
<b>Max Track Weight</b>	24 lbs. maximum

### Spare Parts List:

P/N	Description	Qty/Assy
006-042-0075	120V Standard Inline Coil (7-115)	1
006-042-0077	240V Standard Inline Coil (7-117)	1
045-007-0003	Armature block	1
048-006-0035	Coil mounting bracket	1
079-016-0001	Spring clamp plate	4
079-049-0008	Top plate, 12" inlines	1
088-003-0029	Spring spacer	20
090-001-0003	Thin Spring, fiberglass, 0.095"	4
090-001-0004	Thick Spring, fiberglass, 0.125"	4

### Dimensional Drawing

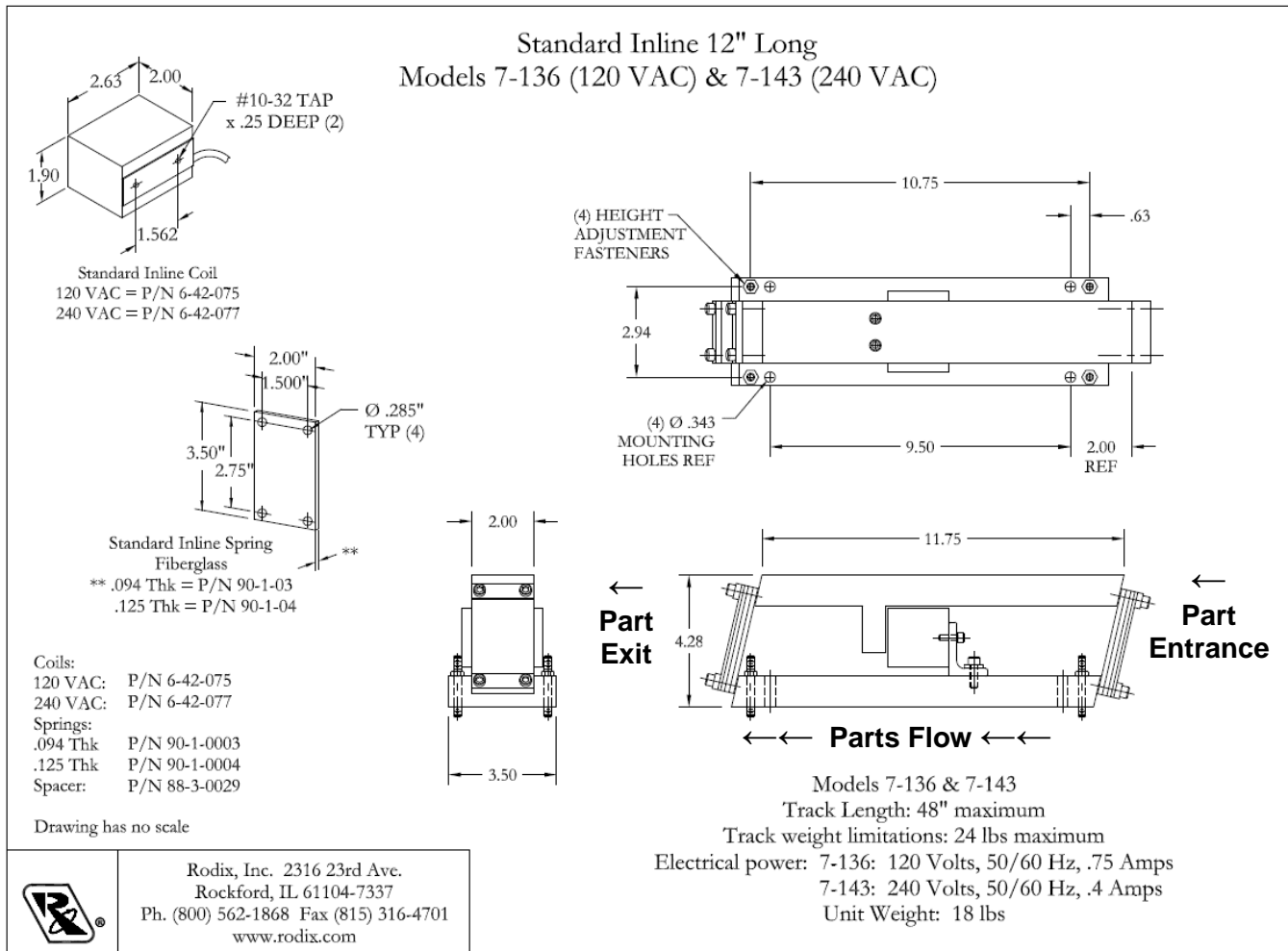

**WARNING**

Never set the gap larger than 0.100 inch or less than 0.030 inches as damage may occur.  
 Do not allow the armature block to hammer against the power coil as damage may occur.  
 Do not apply power to coil without armature block installed or with coil uninstalled from assembly.

**INSTALLATION**

**I. MOUNTING THE INLINE**

The drive must be mounted on a thick, solid steel surface so that it is anchored to a rigid mass that will not absorb the vibration, typically at least 1" thick. If a riser is needed, use solid steel, rather than tube steel or aluminum. The riser should not hang over the edge of the machine table. The table's feet must be leveled. Changing the elevation of the height adjustment fasteners can affect the tuning.

**II. TRACK WEIGHT & LENGTH**

For optimal performance stay within the track length and weight guideline listed on drawing. There is a tradeoff between the track length and weight. When the maximum length is used, the track must be much lighter than the maximum weight. For the best efficiency, the weight of the track should be centered on the drive so that it is balanced.

**III. GAP SETTING**

Loosen the bolt attaching the power coil bracket to the base mounting plate so the coil can be moved by hand. Use feeler gages to set the gap between the armature and power coil at .060 inch. The gap across the coil should be even and the coil should be parallel to the armature block. The electromagnetic coil has a much stronger pull with a smaller gap than a large gap. The ideal gap is the smallest gap possible that allows the feeder to operate at the desired feed rate without the coil hammering against the armature block. Once the ideal gap is determined, tighten the coil bracket bolt so the power coil will not move when operating.

**IV. VIBRATORY FEEDER CONTROL SETTINGS**

**Pulses Per Second (pps)**

The recommended controller setting for standard inline feeders is 60 pps. The 120 pps rate is typically used only for special applications such as with parts that tend to "shingle" in a feed track.

**Power Setting (Amplitude)**

For best results, the power setting on the inline vibratory feeder control should be in the typical operating range of about 40% to 80% when the drive is feeding parts at the optimum rate. After a few hours of operation at the maximum desired feed rate, monitor the coil temperature. It should be cool enough that you can hold your hand on it. If the coil temperature exceeds 140°F, reduce the coil gap and check the spring-tuning or reduce the power setting of the feeder control.

**V. SPRING CONFIGURATION**

Below is the Spring Configuration Chart to assist in setting up the initial spring configuration during tuning. Note that the chart below is meant as a starting point based on actual track weight & parts as is based on a 60 pps controller setting. Alternative spring combinations other than shown below may be required. Reference the Dimensional Drawing for Part Exit & Part Entrance of the inline.

<b>Spring Configuration Chart</b> (Factory Configuration *)		<b>Total Track &amp; Parts Weight (lbs.)</b>
<b>Part Exit</b>	<b>Part Entrance</b>	
1 Thick 0 Thin	1 Thick 0 Thin	0.9
2 Thick 0 Thin	2 Thick 0 Thin	5.9
2 Thick 1 Thin	2 Thick 1 Thin	7.7
<b>2 Thick 2 Thin *</b>	<b>2 Thick 2 Thin *</b>	<b>9.8</b>
5 Thick 4 Thin	5 Thick 4 Thin	23.8
Thick = 0.125" spring P/N 090-003-0004 Thin = 0.094" spring P/N 090-003-0003  <i>Note that for spring configurations larger than factory config, longer SAE 1/4-20 SHCS screws may be required. There are (8) screws per assembly and the factory length is 1.25" for reference to the factory configuration shown above.</i>		