

# RODIX INCORPORATED

2316 23<sup>rd</sup> Ave., ROCKFORD IL 61104

TOLL FREE (800) 562-1868, FAX (815) 316-4701

E-mail [custserve@rodix.com](mailto:custserve@rodix.com)

[www.rodix.com](http://www.rodix.com)

## FEEDER CUBE®

24-210 (120V) and 24-211 (240V) Control Board for FC-40 *Plus Series*

General Purpose Model

IMPORTANT: APPLICATION NOTE



### INSTRUCTIONS FOR REPLACING A 24-480/481 or 24-488/489 with 24-210/211 BOARD.

1. DISCONNECT INCOMING POWER TO THE CONTROL!
2. RECORD THE 60/120 SWITCH SETTINGS.
3. RECORD SOFT START TRIMPOT SETTING.
4. LABEL EACH CIRCUIT BOARD WIRE WITH THE TERMINAL NUMBER.
5. REMOVE WIRES FROM OLD CIRCUIT BOARD.
6. REMOVE OLD CIRCUIT BOARD.
7. INSTALL NEW CIRCUIT BOARD.
8. REWIRE NEW CIRCUIT BOARD ACCORDING TO THE WIRE NUMBERS.
9. SEE SAMPLE WIRING DIAGRAMS FOR REFERENCE.
10. REMOVE TEMPORARY WIRE LABELS.
11. ADJUST THE SWITCH AND TRIMPOT SETTINGS TO MATCH THE OLD CIRCUIT BOARD.
12. RECONNECT POWER TO THE CONTROL.
13. SET UP NEW CONTROL BOARD USING THE APPLICATION NOTE.

Note 1 : Wiring diagrams for specific control models can be downloaded from [www.rodix.com](http://www.rodix.com).



**RODIX INC.**  
**FEEDER CUBE®**  
**FC-40 *Plus Series***  
**General Purpose**

## ADJUSTMENTS & SET UP

### 1. SELECT THE PULSE SETTING

Match the control's pulse mode to the feeder's tuning:

- For 60 pulse output - Set DIP switch (S1) to 60 on the circuit card.
- For 120 pulse output - Set DIP switch (S1) to 120 on the circuit card.
- For 40, 30 or 60 Reverse pulse settings, see the "S1 Programming Chart."

**Note:** Readjust the MAX trimpot after changing pulse switch setting.

### 2. LIMITING THE MAXIMUM OUTPUT OF CONTROL

The **MAX** output trimpot can be adjusted to limit the maximum vibration level of the vibratory feeder when the Main Control Dial is fully turned up. When setting up the MAX output of the feeder control, the output wiring to feeder must be connected and the control set for the proper pulse (60 or 120) setting. The Run Jumper must be connected as shown on the wiring diagram or on the ON/OFF Control Guide.

- Power input should be **OFF** or disconnected.
- Open cover to allow access to circuit card.
- Adjust the **MAX** Output trimpot counter-clockwise to its minimum setting.
- Using **CAUTION**, turn power **ON** (no output should be present).
- Rotate the **MAIN CONTROL DIAL** on front cover clockwise to its highest setting.
- Adjust the **MAX** Output trimpot so that the output to the feeder reaches its desired maximum level.

### 3. SETTING THE MINIMUM OUTPUT LEVEL OF CONTROL

When the vibratory feeder is nearly empty, turn the **MAIN CONTROL DIAL** to "1" and adjust the **MIN** trimpot to just below the slowest speed that provides the proper feed rate. The MIN trimpot also serves as the "low speed" trimpot for 2-speed operation. See "S1 Programming Chart" for feature selection details.

### 4. MAIN CONTROL DIAL

The output power is controlled by the **MAIN CONTROL DIAL**. It is a logarithmic-tapered power out curve (non-linear) that spreads the power broadly across the **MAIN CONTROL DIAL**. The logarithmic taper power curve helps to give maximum "Fine Control" over the output speed of the vibratory feeder. When very precise adjustment of the **MAIN CONTROL DIAL** is needed, increase the MIN trimpot setting and/or decrease the MAX trimpot setting. For precise scaling at low amplitudes, use the linear POT taper or reduce the Max pot setting. To select a linear pot taper for the Main Control Dial, see the "S1 Programming Chart."

### 5. SETTING THE SOFT-START

The start-up rate of the control output can be adjusted to ramp up to the desired output level instead of starting abruptly. Soft-start keeps parts from falling off the tooling, reduces spring shock, and hammering when the control turns ON. Turn the **SOFT** Start trimpot clockwise for the gentlest start (about a 6 sec. ramp up to full output). Turn the trimpot fully counter-clockwise for no soft start.

### 6. REMOTE OFF/ON CONTROL

A Run Jumper has been installed at the factory as shown on the enclosed wiring diagram.

Remote OFF/ON operation of the FC-40 *Plus Series* Feeder Cube® control can be configured to operate in one of the following ways.

- A **low current switch** such as a paddle switch can replace the factory-installed Run Jumper "J1." The "Run Contact" connects to terminals 6 and 7. The contact must be able to switch 5VDC and 2mA. The control will run only when the contact is closed. Refer to Section A of the OFF/ON CONTROL GUIDE.
- Feeder Bowl/Hopper Interlock** allows the Hopper control to operate only when the Bowl is running and the paddle switch contact is closed. The **interlock input** on terminals 11 and 12 of TB2 is controlled by the **interlock output** of a "Parts Sensing Feeder Bowl Control" such as an FC-90 *Plus*

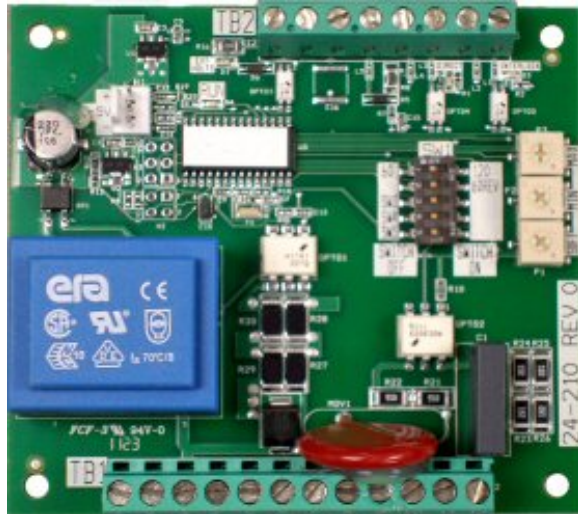

## Model - FC-40 *Plus* Control Boards

**P/N 024-000-0210**  
120 Volt Operation

**P/N 024-000-0211**  
208-240 Volt Operation

Note: Wiring diagrams for specific control models can be downloaded from [www.rodix.com](http://www.rodix.com).

Remove jumper "J1" of this control from terminals 6 and 7. Connect the Hopper Paddle switch to alternate terminals 5 and 6. Connect TB2 terminals 11 and 12 of this control to the "Parts Sensing Control". Refer to Section B of the OFF/ON CONTROL GUIDE. Check specific instructions for the "Parts Sensing Control" wiring. Two FC-40 Series controls will not interlock to each other since neither one has an **interlock output**.

- C. **Low Voltage DC** can be used to turn the control **ON** and **OFF**. Move jumper "J1" from terminal 7, to terminal 5, (6 remains the same). Then connect the positive signal (+5 to 30VDC @ 10mA) to terminal 12 and the negative to terminal 11 of TB2. The control will now turn **ON** when the DC signal is present at terminals 11 and 12 of TB2. This input is optically isolated. Refer to Section C of the OFF/ON CONTROL GUIDE.

### 7. REMOTE SPEED CONTROL

Remote control of the power level can be accomplished by the following methods:

- A. 4-20mA signal from a PLC can be used to remotely vary the output of the control instead of the Main Control Dial. The 4-20mA input is automatically in control whenever a 4-20mA signal is applied to the control (terminals TB2-8 & 9). The Main Control dial setting is ignored whenever there is a 4-20mA signal. The 4-20mA input is transformer isolated from the power line. In an environment with high electrical noise, use a shielded cable for the 4-20mA signal. The "S1 Programming Chart" shows how change to 0-20mA speed control instead of the default of 4-20mA.
- B. A 0-5VDC Analog input signal may be applied in place of the Main Control Dial at H1. The 0-5VDC input is transformer isolated from the power line.

### 8. LINE VOLTAGE COMPENSATION

Fluctuations in the line voltage can cause a feeder bowl to vary its feed rate. The line voltage compensation feature adjusts the control's output to help compensate for fluctuations in the supply voltage. If it becomes necessary to disable this feature, set "Disable LVC" from the S1 programming chart.

### 9. SUPPLEMENTARY FEATURES

Special supplementary software features can be enabled on the 24-210/24-211 circuit boards. The features include: *linear pot taper*, *0-20mA control*, *empty bowl timer*, *low pulse rates*, and *two speed pots*. See the S1 Switch Programming Chart. For more feature information download (or request from RODIX) the FC-40 *Plus* Advanced Application Note 24-210/24-211.

### 10. STATUS LEDs

When any of the inputs are active, the associated LED will turn ON. When the RUN input conditions are met, the RUN LED will turn ON. See section 6 and the wiring diagram's ON/OFF Control Guide for more information on how to satisfy the RUN conditions.

### WARNING:

**Fuses should be replaced with a Bussman ABC or Littelfuse 3AB "Fast Acting" type or equivalent of manufacturer's original value.**

**Mounting this control on a vibrating surface will void the warranty.**

### WARRANTY

**Rodix Control Products are Warranted to be free from defects in material and workmanship under normal use for a period of two years from date of shipment.** For the full description of the warranty, terms, and software license, please contact the factory.

For assistance installing or operating your Rodix Feeder Cube® please call the factory or visit our web site. Technical help is available to answer your questions and fax any needed information. To return a control for IN or OUT of warranty service, please ship it prepaid to:

**Rodix Inc., ATTN: Repair Department**

If under warranty, Rodix will repair or replace your control at no charge; If out of warranty, we will repair it and you will be billed for the repair charges (Time and Material) plus the return freight. Quotes for repairs are available upon request. A brief note describing the symptoms helps our technicians address the issue.

Feeder Cube® is a registered TM of Rodix Inc.

### DIMENSIONS

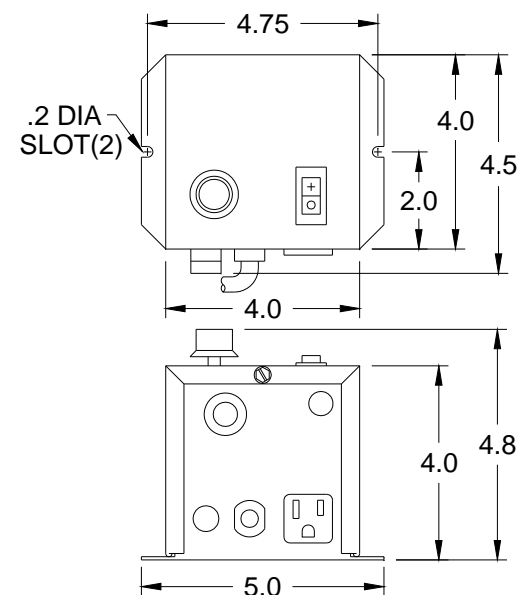

### S1 Programming Chart

Program Description	S1 Switch Positions		
	SW3	SW4	SW5
Standard Program	0	0	0
Linear Pot Taper	1	0	0
0-20mA option	0	1	0
Empty Bowl Timer	1	1	0
Disable LVC	0	0	1
2-Speed Operation	1	0	1
30/40 Pulse Operation	0	1	1
Spare	1	1	1

### RODIX, INC.

2316 23<sup>rd</sup> Ave., Rockford, IL 61104  
Toll Free (800) 562-1868, FAX (815) 316-4701  
E-mail [custserve@rodix.com](mailto:custserve@rodix.com)  
[www.rodix.com](http://www.rodix.com)

## OFF/ON CONTROL GUIDE

See section 6 of the FC-40 Plus Series models for more information.

### A) LOW CURRENT SWITCH

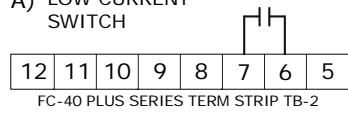

### B) FEEDER BOWL/HOPPER INTERLOCK

FC-90 PLUS SERIES  
TERM STRIP TB-2, OUTPUT

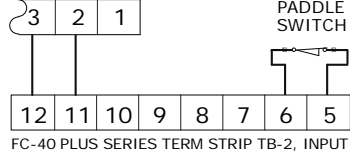

### C) LOW VOLTAGE INPUT SWITCHING (DC Voltage from PLC or FC-90 Plus) 5-30 VDC INPUT VOLTAGE OFF/ON CONTROL

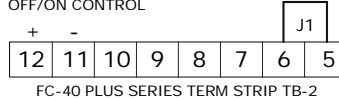

## Oil Resistant 120 Volt Connections

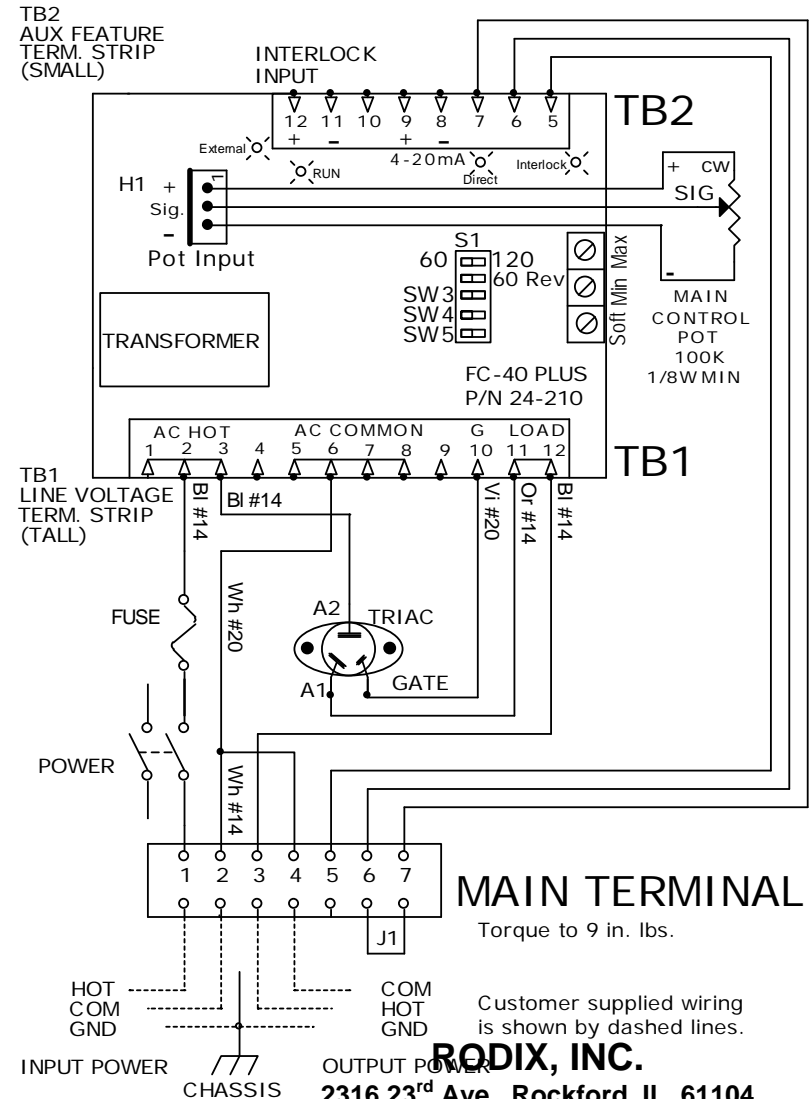
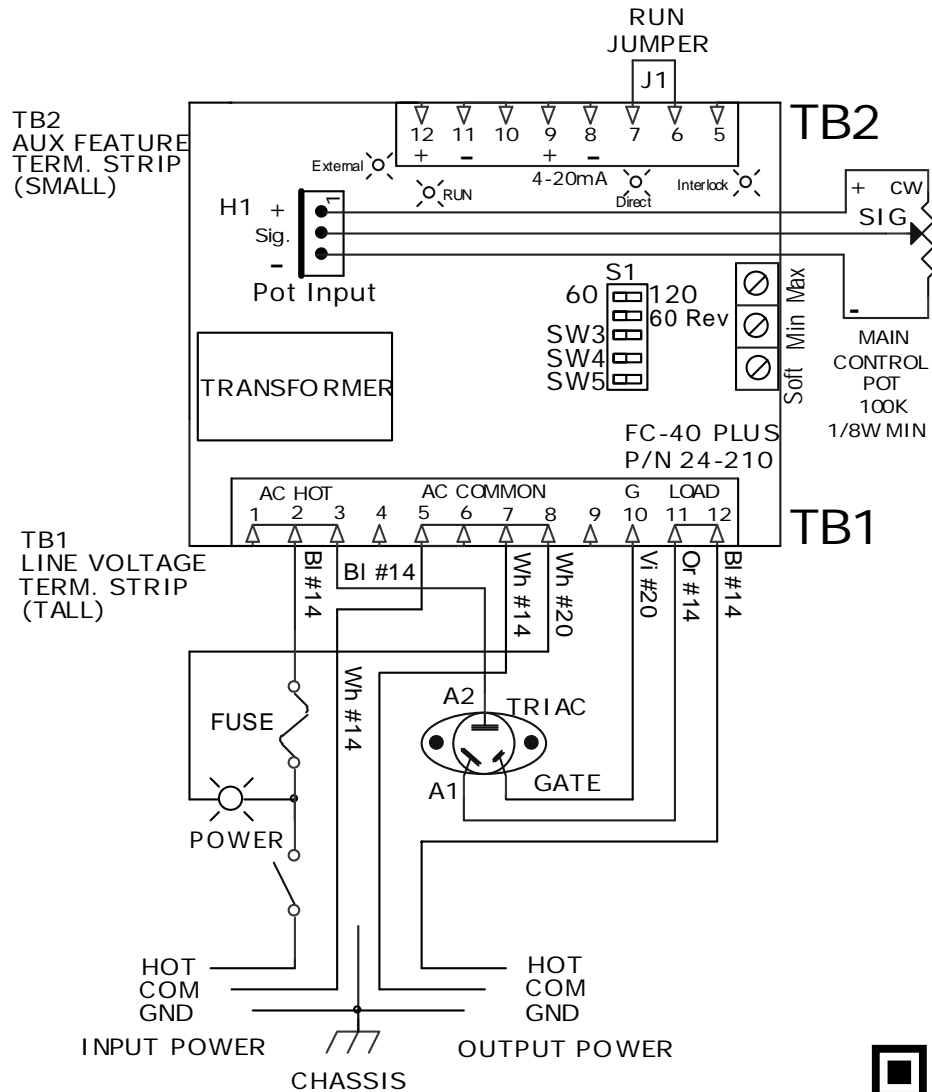

## General Purpose and Open Frame 120 Volt Connections



**RODIX, INC.**  
2316 23<sup>rd</sup> Ave., Rockford, IL 61104  
Toll Free (800) 562-1868, FAX (815) 316-4701  
Email [custserve@rodix.com](mailto:custserve@rodix.com)  
[www.rodix.com](http://www.rodix.com)  
24-210 24-211 Board App Note 5/31/2012 Page 3

## OFF/ON CONTROL GUIDE

See section 6 of for the FC-40 Plus Series models for more information.

### A) LOW CURRENT SWITCH

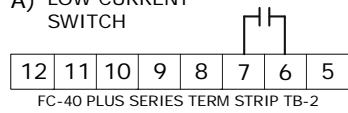

### B) FEEDER BOWL/HOPPER INTERLOCK

FC-90 PLUS SERIES  
TERM STRIP TB-2, OUTPUT

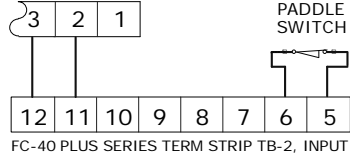

### C) LOW VOLTAGE INPUT SWITCHING (DC Voltage from PLC or FC-90 Plus) 5-30 VDC INPUT VOLTAGE OFF/ON CONTROL

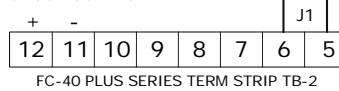

## Oil Resistant 208-240 Volt Connections

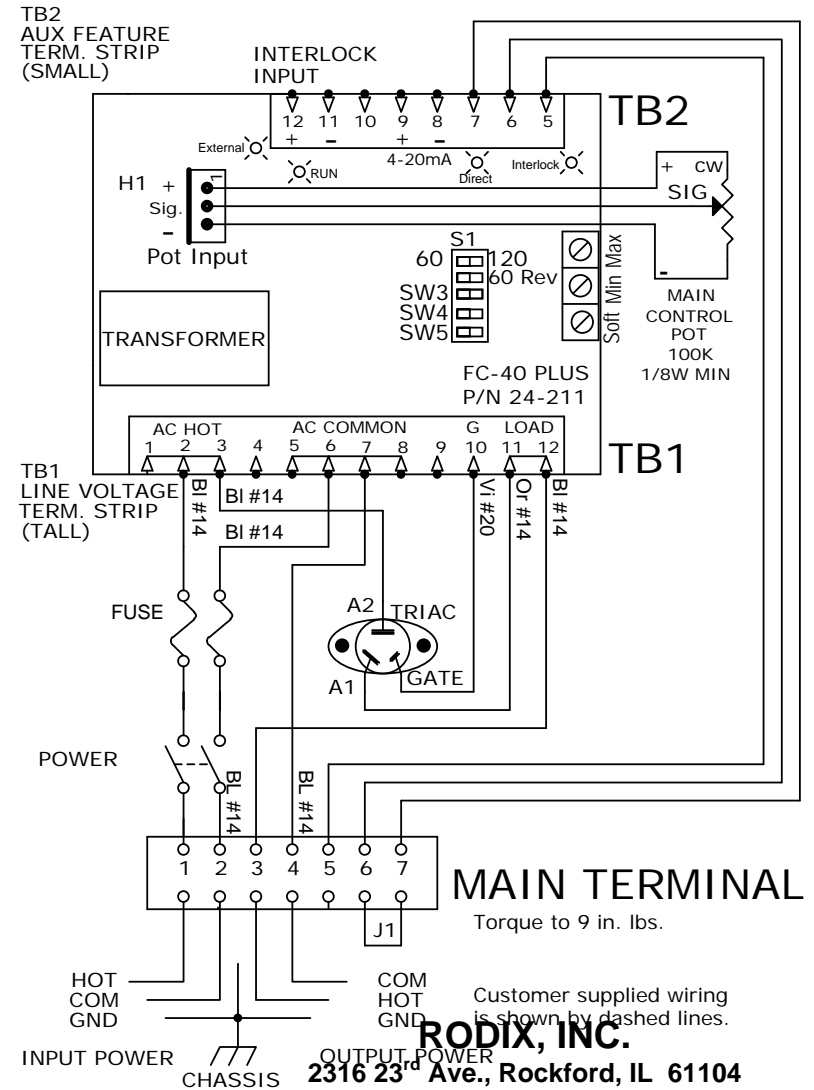
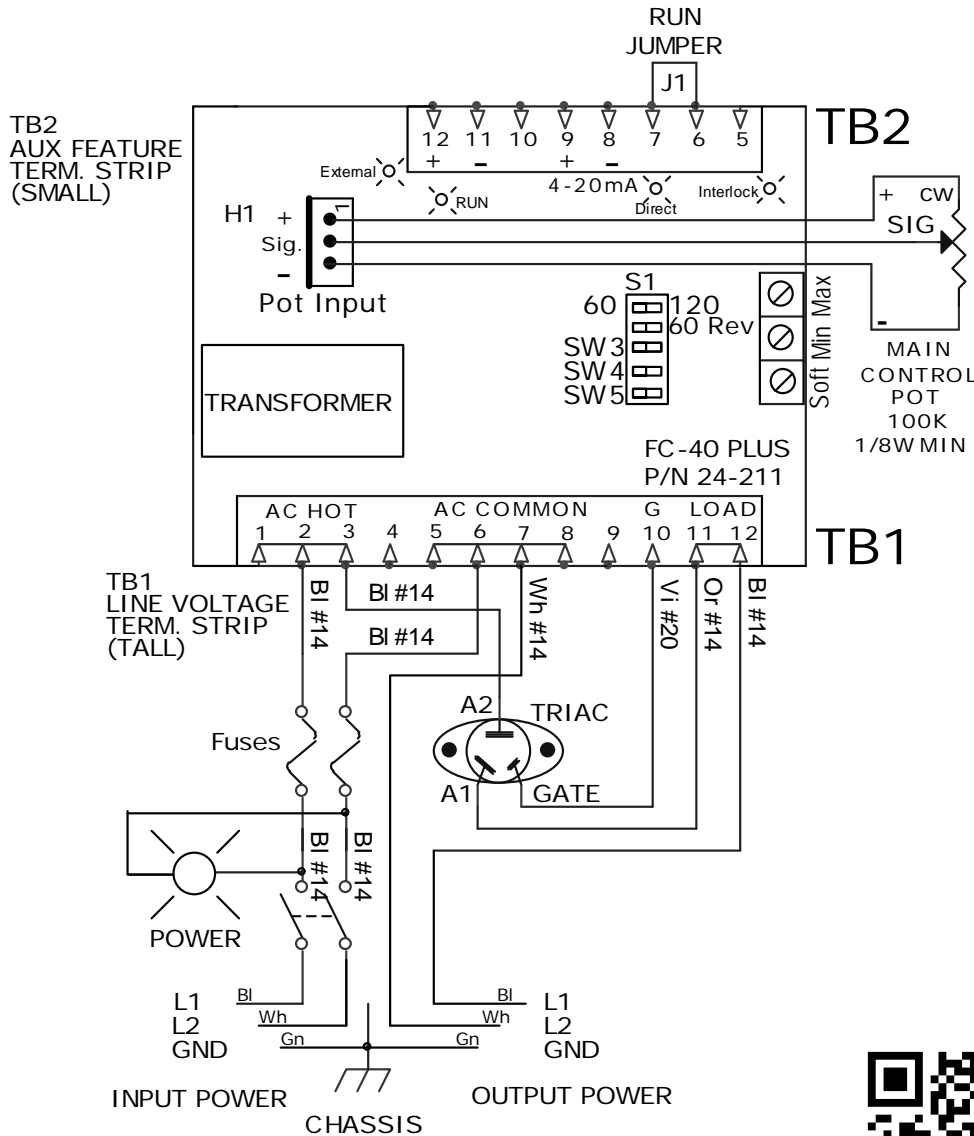

## General Purpose and Open Frame 208-240 Volt Connections



**RODIX, INC.**  
2316 23<sup>rd</sup> Ave., Rockford, IL 61104  
Toll Free (800) 562-1868, FAX (815) 316-4701  
Email [custserve@rodix.com](mailto:custserve@rodix.com)  
[www.rodix.com](http://www.rodix.com)  
24-210 24-211 Board App Note 5/31/2012 Page 4