

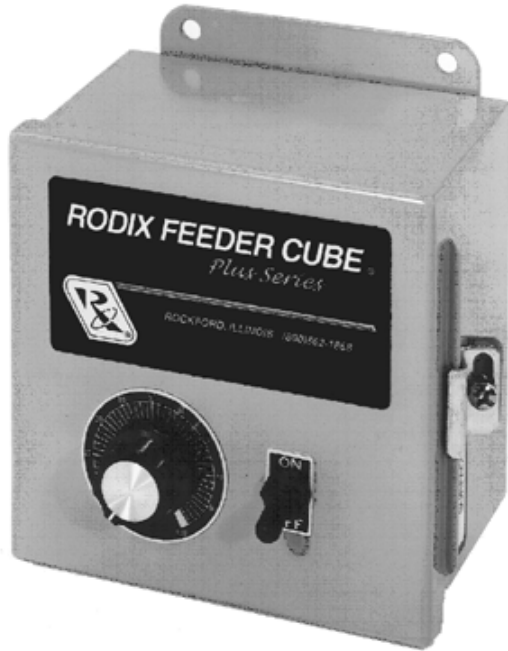

RODIX INC.
FEEDER CUBE®
FC-40 Plus Series
Oil Resistant



Model - FC-41-DC *Plus*

P/N 121-000-0903

Circuit Board P/N 24-210

Input: 120 VAC, 50/60 HZ.

(Operating range 90-130 VAC)

Single Unit Fuse Size: 10 AMPS

Output: 0-90/130 VDC

80% Duty Cycle at Rated AMPS

© 2000, 2011 RODIX INC.

ADJUSTMENTS & SET UP

1. SELECT THE PULSE SETTING

Set DIP switch (S1) to 120 on the circuit card.

Note: Readjust the MAX trimpot after changing pulse switch setting.

2. FUSE SIZE

To avoid failure of the DC motor, the fuse on this control must be resized to match the fuse size listed on the motor nameplate. Do not exceed 10 Amps maximum.

3. LIMITING THE MAXIMUM OUTPUT OF CONTROL

The **MAX** output trimpot can be adjusted to limit the maximum vibration level of the vibratory feeder when the Main Control Dial is fully turned up. When setting up the MAX output of the feeder control, the output wiring to feeder must be connected and the control set for the proper pulse (60 or 120) setting. The Run Jumper must be connected as shown on the wiring diagram or on the ON/OFF Control Guide.

- A. Power input should be **OFF** or disconnected.
- B. Open cover to allow access to circuit card.
- C. Adjust the **MAX** Output trimpot counter-clockwise to its minimum setting.
- D. Using **CAUTION**, turn power **ON** (no output should be present).
- E. Rotate the **MAIN CONTROL DIAL** on front cover clockwise to its highest setting.
- F. Adjust the **MAX** Output trimpot so that the output to the feeder reaches its desired maximum level.

4. SETTING THE MINIMUM OUTPUT LEVEL OF CONTROL

Turn the **MAIN CONTROL DIAL** to "1" and adjust the **MIN** trimpot to just below the slowest speed that provides the proper feed rate. For operation at very low speeds, select the "Low Voltage at 1" program. See "S1 Programming Chart" for feature selection details. The MIN trimpot also serves as the "low speed" trimpot for 2-speed operation.

5. MAIN CONTROL DIAL

The output power is controlled by the **MAIN CONTROL DIAL**. It is a logarithmic-tapered power out curve (non-linear) that spreads the power broadly across the **MAIN CONTROL DIAL**. The logarithmic taper power curve helps to give maximum "Fine Control" over the output speed of the vibratory feeder. When very precise adjustment of the **MAIN CONTROL DIAL** is needed, increase the MIN trimpot setting and/or decrease the MAX trimpot setting. For precise scaling at low amplitudes, use the linear POT taper or reduce the Max pot setting. To select a linear pot taper for the Main Control Dial, see the "S1 Programming Chart."

6. SETTING THE SOFT-START

The start-up rate of the control output can be adjusted to ramp up to the desired output level instead of starting abruptly. Soft-start keeps parts from falling off the tooling, reduces spring shock, and hammering when the control turns ON. Turn the **SOFT** Start trimpot clockwise for the gentlest start (about a 6 sec. ramp up to full output). Turn the trimpot fully counter-clockwise for no soft start.

7. REMOTE OFF/ON CONTROL

A Run Jumper has been installed at the factory as shown on the enclosed wiring diagram.

Remote OFF/ON operation of the FC-40 *Plus Series* Feeder Cube® control can be configured to operate in one of the following ways.

- A. A **low current switch** such as a paddle switch can replace the factory-installed Run Jumper "J1." The "Run Contact" connects to terminals 6 and 7. The contact must be able to switch 5VDC and 2mA. The control will run only when the contact is closed. Refer to Section A of the OFF/ON CONTROL GUIDE.
- B. **Feeder Bowl/Hopper Interlock** allows the Hopper control to operate only when the Bowl is running and the paddle switch contact is closed. The **interlock input** on terminals 11 and 12 of TB2 is controlled by the **interlock output** of a "Parts Sensing Feeder Bowl Control" such as an FC-90 *Plus*

Remove jumper "J1" of this control from terminals 6 and 7. Connect the Hopper Paddle switch to alternate terminals 5 and 6. Connect TB2 terminals 11 and 12 of this control to the "Parts Sensing Control". Refer to Section B of the OFF/ON CONTROL GUIDE. Check specific instructions for the "Parts Sensing Control" wiring. Two FC-40 Series controls will not interlock to each other since neither one has an **interlock output**.

- C. **Low Voltage DC** can be used to turn the control **ON** and **OFF**. Move jumper "J1" from terminal 7, to terminal 5, (6 remains the same). Then connect the positive signal (+10 to 30VDC @ 10mA) to terminal 12 and the negative to terminal 11 of TB2. The control will now turn **ON** when the DC signal is present at terminals 11 and 12 of TB2. This input is optically isolated. Refer to Section C of the OFF/ON CONTROL GUIDE.

8. REMOTE SPEED CONTROL

Remote control of the power level can be accomplished by the following methods:

- A. 4-20mA signal from a PLC can be used to remotely vary the output of the control instead of the Main Control Dial. The 4-20mA input is automatically in control whenever a 4-20mA signal is applied to the control (terminals TB2-8 & 9). The Main Control dial setting is ignored whenever there is a 4-20mA signal. The 4-20mA input is transformer isolated from the power line. In an environment with high electrical noise, use a shielded cable for the 4-20mA signal. The "S1 Programming Chart" shows how change to 0-20mA speed control instead of the default of 4-20mA.
- B. A 0-5VDC Analog input signal may be applied in place of the Main Control Dial at H1. The 0-5VDC input is transformer isolated from the power line.

9. LINE VOLTAGE COMPENSATION

Fluctuations in the line voltage can cause a feeder bowl to vary its feed rate. The line voltage compensation feature adjusts the control's output to help compensate for fluctuations in the supply voltage. If it becomes necessary to disable this feature, set "Disable LVC" from the S1 programming chart.

10. SUPPLEMENTARY FEATURES

Special supplementary software features can be enabled on the 24-210/24-211 circuit boards. The features include: *linear pot taper*, *0-20mA control*, *empty bowl timer*, *low pulse rates*, and *two speed pots*. See the S1 Switch Programming Chart. For more feature information download (or request from RODIX) the FC-40 *Plus* Advanced Application Note 24-210/24-211.

11. STATUS LEDs

When any of the inputs are active, the associated LED will turn ON. When the RUN input conditions are met, the RUN LED will turn ON. See section 6 and the wiring diagram's ON/OFF Control Guide for more information on how to satisfy the RUN conditions.

WARNING:

Fuses should be replaced with a Bussman ABC or Littelfuse 3AB "Fast Acting" type or equivalent of manufacturer's original value.

Mounting this control on a vibrating surface will void the warranty.

WARRANTY

Rodix Control Products are Warranted to be free from defects in material and workmanship under normal use for a period of two years from date of shipment. For the full description of the warranty, terms, and software license, please contact the factory.

For assistance installing or operating your Rodix Feeder Cube® please call the factory or visit our web site. Technical help is available to answer your questions and fax any needed information. To return a control for IN or OUT of warranty service, please ship it prepaid to:

Rodix Inc., ATTN: Repair Department

If under warranty, Rodix will repair or replace your control at no charge; If out of warranty, we will repair it and you will be billed for the repair charges (Time and Material) plus the return freight. Quotes for repairs are available upon request. A brief note describing the symptoms helps our technicians address the issue.

Feeder Cube® is a registered TM of Rodix Inc.

TROUBLESHOOTING

For the control to run: The **MAIN CONTROL DIAL** must be turned up or have over 4mA at the 4-20mA input. Either the **DIRECT LED** must be lit or both the **INTERLOCK** and **EXT VOLTS LEDs** must be on. To

light the **DIRECT LED**, connect a Run Jumper at Terminals 6 & 7. To light the **INTERLOCK LED**, a Run Jumper must connect Terminal 5 to 6. To illuminate the **EXT VOLTS LED**, TB2-11 & 12 needs a 10-30 VDC signal. See the "FC-40 Plus Troubleshooting Guide" for more information. If the motor is noisy, flip the 60/120 dip switch to 120.

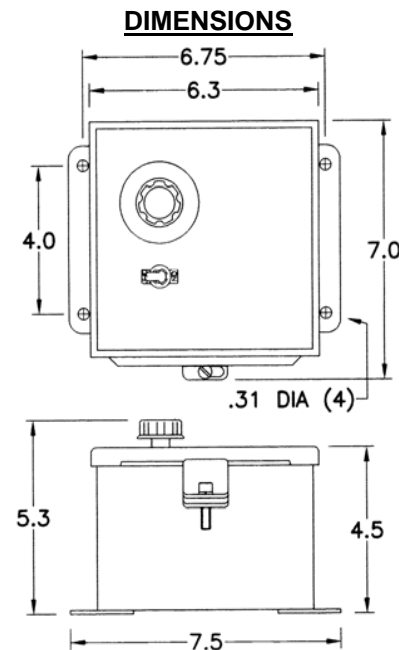

S1 Programming Chart

Program Description	S1 Switch Positions		
	SW3	SW4	SW5
Standard Program	0	0	0
Linear Pot Taper	1	0	0
0-20mA option	0	1	0
Empty Bowl Timer	1	1	0
Disable LVC	0	0	1
2-Speed Operation	1	0	1
30/40 Pulse Operation	0	1	1
Low Amplitude at "1"	1	1	1

RODIX, INC.

2316 23rd Ave., Rockford, IL 61104
Toll Free (800) 562-1868, FAX (815) 316-4701
E-mail custserve@rodix.com
www.rodix.com

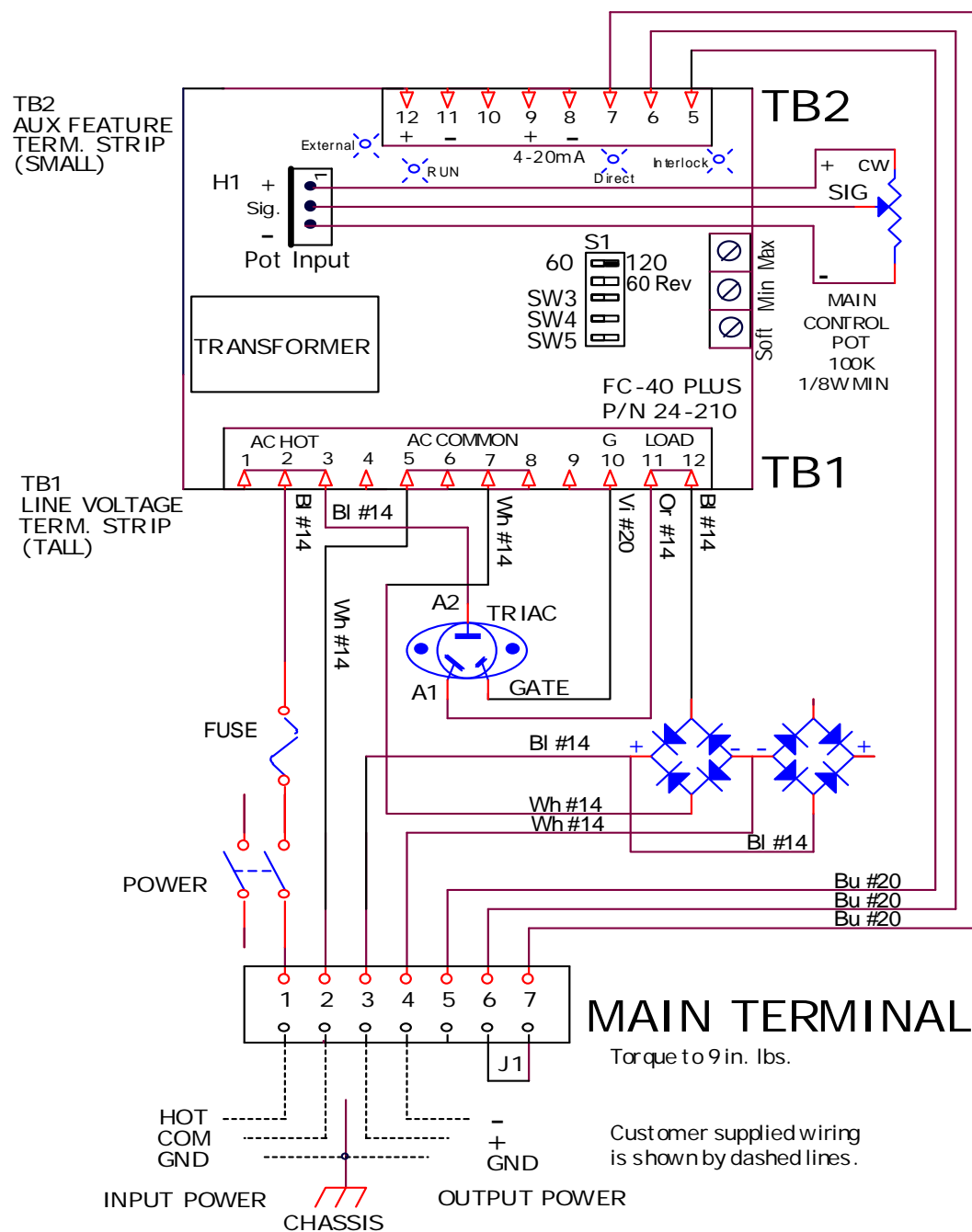

OFF/ON CONTROL GUIDE

See section 6 of the Application Note for more details on the REMOTE OFF/ON CONTROL guide.

A) LOW CURRENT SWITCH

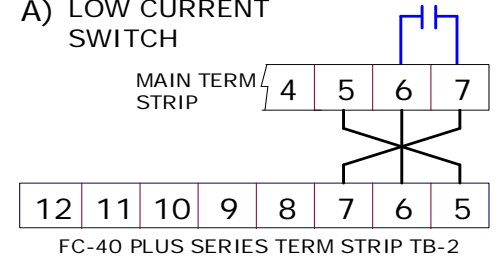

B) FEEDER BOWL/HOPPER INTERLOCK

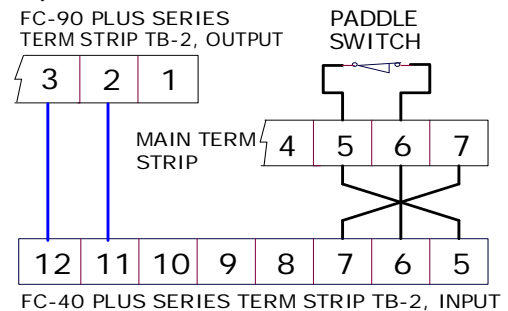

C) LOW VOLTAGE INPUT SWITCHING (DC Voltage from PLC or FC-90 Plus)

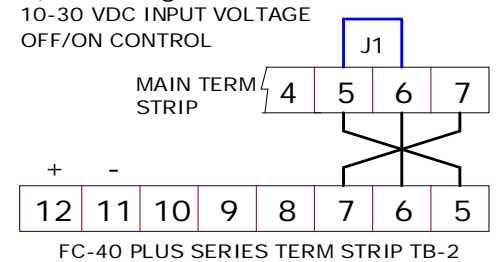

MODEL	INPUT VAC	AMPS	OUTPUT VDC
FC-41-DC Plus	120 VAC	10	0-90/130

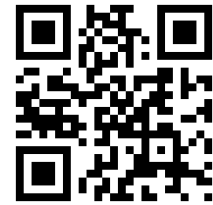



RODIX SOLUTION

Good wiring practices for avoiding electrical noise problems.

Rodix controls have been designed with a high degree of immunity to electrical noise; however, depending on the control installation, electrical noise can cause problems. These problems occur in less than 1% of the product installations. Most electrical noise problems can be avoided by following some simple guidelines. Good wiring practices need to be used to prevent electrical noise from interfering with your control's operation. Another name for electrical noise is Electro-Magnetic Interference (EMI).

Symptoms of Electrical Noise

The symptoms of electrical noise would appear as follows: a brief pause or a brief "bump" in the vibratory feeder's output that the control automatically recovers from. In rare cases the control will either stop operating or run continuously at full power in 120 pulse mode until the power switch is slowly cycled OFF and ON.

Sources of Electrical Noise

Electrical noise is generated by devices like relay coils, solenoid valves, contactors, servo motors, and variable

frequency inverter drives. The electrical noise is then transferred to another device by one of three ways. The noise could be conducted through the power wires, or capacitively coupled from wire to adjacent wire, or it is transmitted from the wires of a nearby noise source.

Solutions for Electrical Noise

1. Use shielded wires for all I/O (Input / Output) signals. The I/O signals may include: 4-20mA input, Run input, Sensor input, 0-5VDC input, Interlock input or AUX output. The shield "drain" wire should be tied to the chassis in the Rodix control. The drain wire should be kept shorter than 2". Please see the enclosed picture.

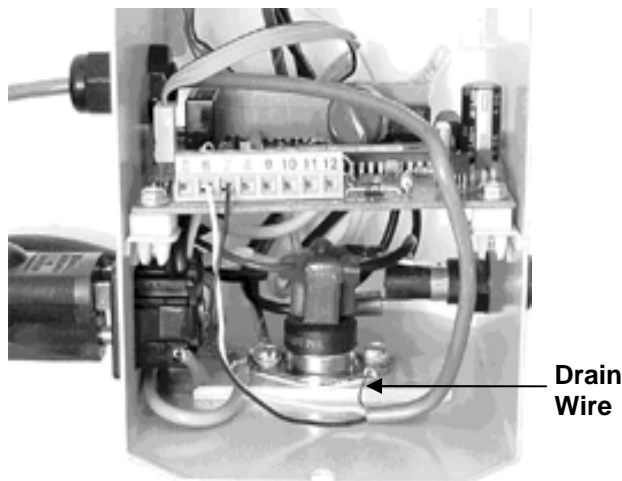

Example of a "drain" wire termination

2. Never run I/O signal wires in the same conduit or raceway as AC power lines such as wires to motors, solenoids, heaters, welders and Rodix controls, etc.

3. I/O wires within an enclosure should be routed as far away as possible from relays, solenoids, transformers, power wiring and other noisy equipment. Keep the I/O signal wires separate from the control's input and output power wiring. Secure the wires in place.

4. Whenever relays or solenoid valves are used, install a Snubber on them to reduce electrical noise. Use a diode on a DC coil. Use a RC Snubber on an AC coil.

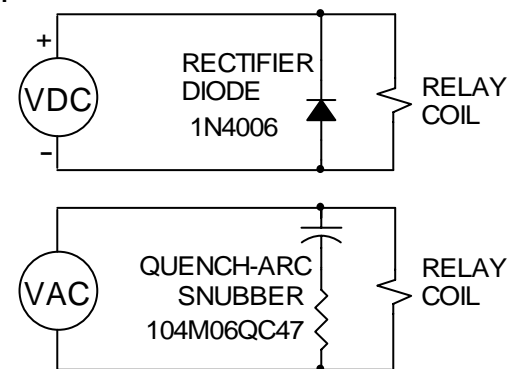

5. In extremely high EMI environments, Power Line Filters and ferrite beads can be effective. Install ferrite beads on I/O signal wires as close as possible to the circuit board terminal strip. Loop the wire through the bead several times or use several beads on each wire for additional protection.

RODIX, INC.

2316 23rd Avenue, Rockford, IL 61104
 Toll Free (800) 562-1868, FAX (815) 316-4701
 E-mail custserve@rodix.com
www.rodix.com