



RODIX INC.
FEEDER CUBE®
FC-70 SERIES
General Purpose



Model - FC-70H *Plus*

P/N 121-000-1113

Circuit Board P/N 24-219

Input: 120 VAC, 50/60 HZ.

(Operating range 100-130 VAC)

Single Unit Fuse Size: 10 AMPS

Output: 0-120 VAC

© 2015 RODIX INC.

ADJUSTMENTS AND SET UP

Warning: To avoid shock, remove power before making any changes to the circuit board settings or connections. The control is not isolated from the power line.

1. SELECT THE PULSE SETTING

Match the control's pulse mode to the feeder's tuning:

- A. For 60 pulse output - Set DIP switch (S1, position 1) to 60 on the circuit card.
- B. For 120 pulse output - Set DIP switch (S1, position 1) to 120 on the circuit card.
- C. For 60 Reverse pulse setting see the "Feature Programming Chart". The "60 Pulse Reverse" feature is useful for reducing mechanical vibration interaction between different feeder components mounted on the same machine table. To determine if there is a feeder interaction, remove the power from one feeder. If a feeder interaction exists, the feed rate on the other feeder will either speed up or slow down.
- D. For 40 pulse output see the "Feature Programming Chart". The 40 Pulse rate can be useful in a minority of applications for feeding heavy parts. The power output is not as high as 60 pulse mode. A vibratory feeder that is converted to a lower pulse mode will require fewer springs.

2. AMPLITUDE POT

The output power is controlled by the **AMPLITUDE POT**. It is a logarithmic-tapered power out curve (non-linear) that spreads the power broadly across the **AMPLITUDE POT**. The logarithmic taper power curve helps to give maximum "Fine Control" over the output speed of the vibratory feeder.

3. SETTING THE SOFT-START

The start-up rate of the control's output can be set to ramp up to the desired output level instead of starting abruptly. The Soft-start keeps parts from falling off the tooling, reduces spring shock, and hammering

when the control turns ON. Set position 2 of S1 DIP switch to the ON position to enable the two second **SOFT** Start function. Set position 2 of S1 DIP switch to the OFF position to disable the **SOFT** Start function.

4. REMOTE OFF/ON CONTROL

A Run Jumper has been installed at the factory as shown on the enclosed wiring diagram.

Remote OFF/ON operation of the FC-70 Series Feeder Cube® control can be configured to operate in one of the following ways.

- A. A **low current switch** such as a paddle switch can replace the factory-installed Run Jumper "J1." The "Run Contact" connects to terminals TB2-3 and 4. The contact must be isolated and be able to switch 24VDC and 2mA. The control will run when the contact is closed. Refer to Section A of the OFF/ON CONTROL GUIDE.
- B. **Low Voltage DC** can be used to turn the control **ON** and **OFF**. Remove jumper "J1" from TB2 terminals 3 and 4. Then connect the positive signal (+12 to 24VDC @ 5mA) to TB2 terminal 2 and the negative to terminal 1 of TB2. The control will now turn **ON** when the DC signal is present at terminals 1 and 2 of TB2. This input is optically isolated. Refer to Section B of the OFF/ON CONTROL GUIDE.

There is a "RUN" status LED that lights up when either the low current switch is closed or when an external low voltage DC signal is applied. The control's output will be ON whenever the "RUN" LED is lit and the AMPLITUDE POT is turned up.

5. LINE VOLTAGE COMPENSATION

Fluctuations in the line voltage can cause a feeder bowl to vary its feed rate. The line voltage compensation feature adjusts the control's output to help compensate for fluctuations in the supply voltage. If it becomes necessary to disable this feature, remove resistor "R20" from the circuit board. R20 is located near the Triac labeled Q1. With the input power disconnected, a knife can be used to cut down through "R20".

6. FEATURE PROGRAMMING CHART

“X” means the setting could be in either position because the position doesn’t matter.

“0” means the “resistor” jumper has been removed.

Feature Programming Chart			
Program Description	SW1	R24	R25
Standard Program	X	1	1
60 Pulse Reverse	60	0	X
40 Pulse Operation	120	0	X
Low Voltage at “1”	X	X	0

7. LOW VOLTAGE AT “1”

Some small feeders may feed faster than desired at low settings on the dial. The “Low Voltage at 1” program allows the control’s output to operate at a much lower minimum voltage than the standard minimum voltage. To enable this feature break through resistor R25 with a knife.

TROUBLESHOOTING

For the control to run: The **AMPLITUDE POT** must be turned up and the RUN LED must be lit. To light the RUN LED, connect a Run Jumper from TB2 terminal 3 to 4, or apply a 10-30 VDC signal at TB2 terminals 1 & 2. See the “FC-70 Troubleshooting Guide” for more information. If the feeder only hums or barely moves parts, toggle the 60/120 dip switch to match the feeder’s tuning.

WARNING:

Fuses should be replaced with a Bussman ABC or Littelfuse 3AB "Fast Acting" type or equivalent of manufacturer's original value.

Mounting this control on a vibrating surface will void the warranty.

WARRANTY

Rodix Control Products are Warranted to be free from defects in material and workmanship under normal use for a period of two years from date of shipment. For the full description of the warranty, terms, and software license, please contact the factory.

For assistance installing or operating your Rodix Feeder Cube® please call the factory or visit our web site. Technical help is available to answer your questions and email any needed information. To return a control for IN or OUT of warranty service, please ship it prepaid to:

Rodix Inc., ATTN: Repair Department

If under warranty, Rodix will repair or replace your control at no charge; If out of warranty, we will repair it and you will be billed for the repair charges (Time and Material) plus the return freight. Quotes for repairs are available upon request. A brief note describing the symptoms helps our technicians address the issue.

Feeder Cube® is a registered TM of Rodix Inc.

Dimensions

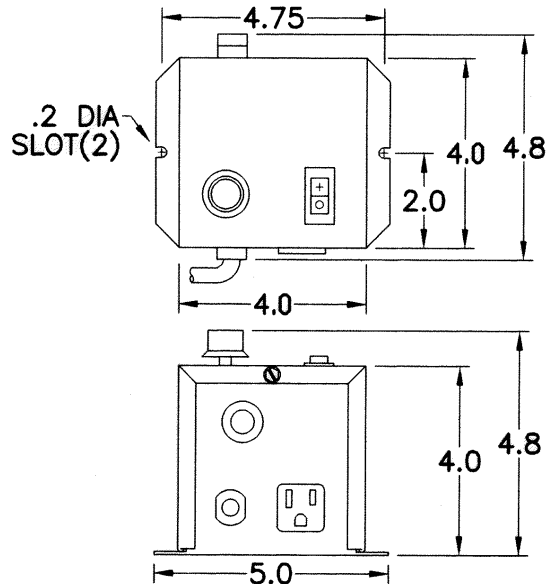

RODIX, INC.

2316 23rd Ave., Rockford, IL 61104
Toll Free (800) 562-1868, FAX (815) 316-4701
E-mail custserve@rodix.com
www.rodix.com

OFF/ON CONTROL GUIDE

See section 4 of the Application Note for more details on the REMOTE OFF/ON CONTROL guide.

A) LOW CURRENT SWITCH

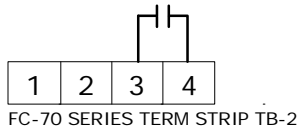

B) LOW VOLTAGE INPUT SWITCHING (DC Voltage from PLC or FC-90 Plus)

10-30 VDC INPUT VOLTAGE
OFF/ON CONTROL

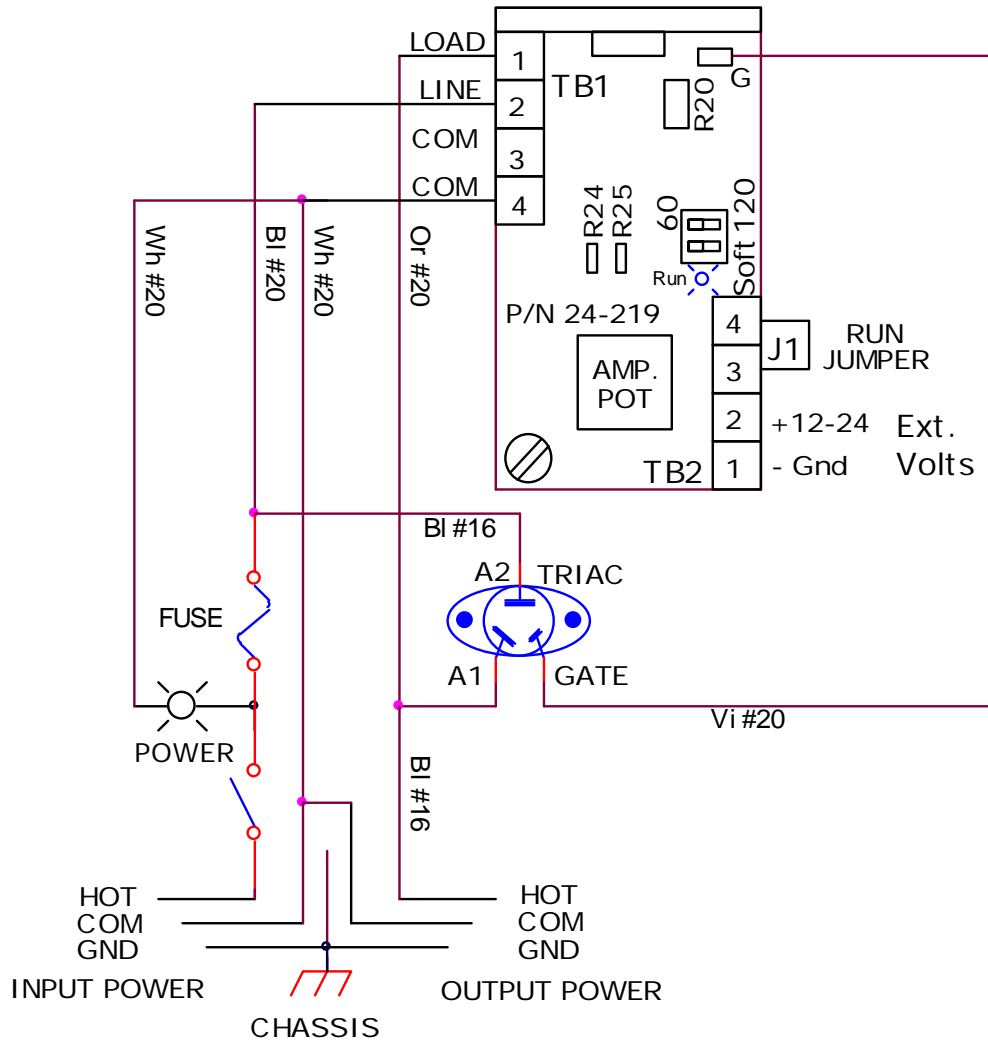
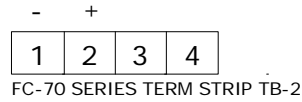

MODEL	INPUT VAC	AMPS	OUTPUT
FC-70H	120 VAC	10	0-120 V

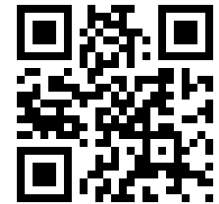

RODIX, INC.
 2316 23rd Ave., Rockford, IL 61104
 Toll Free (800) 562-1868, FAX (815) 316-4701
 Email custserve@rodix.com
www.rodix.com
 FC-70H 24-219.doc 5/14/2015 Page 3



RODIX SOLUTION

Good wiring practices for avoiding electrical noise problems.

Rodix controls have been designed with a high degree of immunity to electrical noise; however, depending on the control installation, electrical noise can cause problems. These problems occur in less than 1% of the product installations. Most electrical noise problems can be avoided by following some simple guidelines. Good wiring practices need to be used to prevent electrical noise from interfering with your control's operation. Another name for electrical noise is Electro-Magnetic Interference (EMI).

Symptoms of Electrical Noise

The symptoms of electrical noise would appear as follows: a brief pause or a brief "bump" in the vibratory feeder's output that the control automatically recovers from. In rare cases the control will either stop operating or run continuously at full power in 120 pulse mode until the power switch is slowly cycled OFF and ON.

Sources of Electrical Noise

Electrical noise is generated by devices like relay coils, solenoid valves, contactors, servo motors, and variable

frequency inverter drives. The electrical noise is then transferred to another device by one of three ways. The noise could be conducted through the power wires, or capacitively coupled from wire to adjacent wire, or it is transmitted from the wires of a nearby noise source.

Solutions for Electrical Noise

1. Use shielded wires for all I/O (Input / Output) signals. The I/O signals may include: 4-20mA input, Run input, Sensor input, 0-5VDC input, Interlock input or AUX output. The shield "drain" wire should be tied to the chassis in the Rodix control. The drain wire should be kept shorter than 2". Please see the enclosed picture.

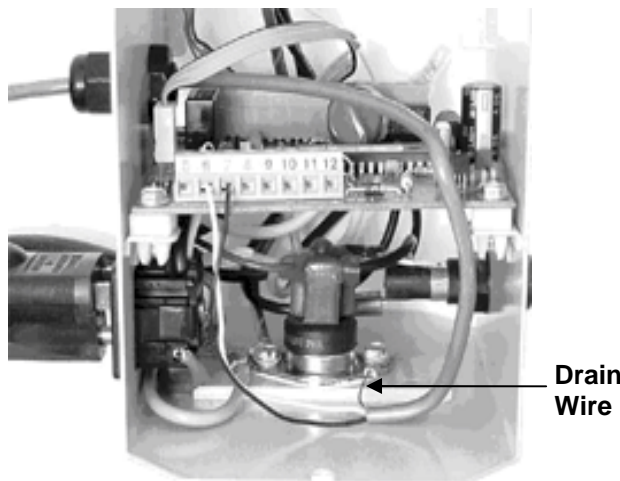

Example of a "drain" wire termination

2. Never run I/O signal wires in the same conduit or raceway as AC power lines such as wires to motors, solenoids, heaters, welders and Rodix controls, etc.

3. I/O wires within an enclosure should be routed as far away as possible from relays, solenoids, transformers, power wiring and other noisy equipment. Keep the I/O signal wires separate from the control's input and output power wiring. Secure the wires in place.

4. Whenever relays or solenoid valves are used, install a Snubber on them to reduce electrical noise. Use a diode on a DC coil. Use a RC Snubber on an AC coil.

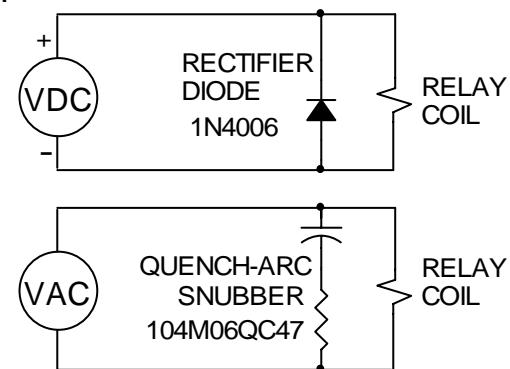

5. In extremely high EMI environments, Power Line Filters and ferrite beads can be effective. Install ferrite beads on I/O signal wires as close as possible to the circuit board terminal strip. Loop the wire through the bead several times or use several beads on each wire for additional protection.

RODIX, INC.

2316 23rd Avenue, Rockford, IL 61104
 Toll Free (800) 562-1868, FAX (815) 316-4701
 E-mail custserve@rodix.com
www.rodix.com