



RODIX INCORPORATED

TOLL FREE (800) 562-1868, FAX (815) 316-4701

E-mail custserve@rodix.com
rodix.com

FEEDER CUBE®

VFC-9-201-2, P/N 121-200-0785

OIL RESISTANT MODEL

IMPORTANT: APPLICATION NOTE

Input: 120 VAC, 50/60 HZ.

(Operating range 90-130 VAC)

Outputs: 0 - 120 VAC

Rated for IP54 environment

Unit A ratings

Input Fuse Size: 5 amps

Output Frequency: 5 - 300Hz

Rated Output Current: 9 Amps

Units B & C ratings

Input Fuse Size: 15 amps

Output Frequency: Same as Utility Frequency

Output Current: 100% Duty Cycle 0.6-12A per unit, 80% for 13-15A

Unit A Information: The Autotune Series of Variable Frequency Feeder Cubes® generates an output frequency for feeding that is independent from the power line frequency. An optional vibration sensor, P/N 123-215, can be used to maintain the vibratory feeder at a constant feed rate. The start/stop operation of the output can be controlled with an optional parts sensor. For more information on this control, refer to the enclosed Adjustments and Set Up pages.

Units B & C Information: These units are based on the FC-200 Series Part Sensing Feeder Cube®. The start/stop operation of the output can be controlled with an optional parts sensor. For more information on these units, refer to the enclosed Adjustments and Set Up pages. Unit B is interlocked (subordinate) to the operation of Unit A so that Unit B operates only when Unit A is feeding parts. The Unit C operation is independent of the other units. The interlocks can be reconfigured.

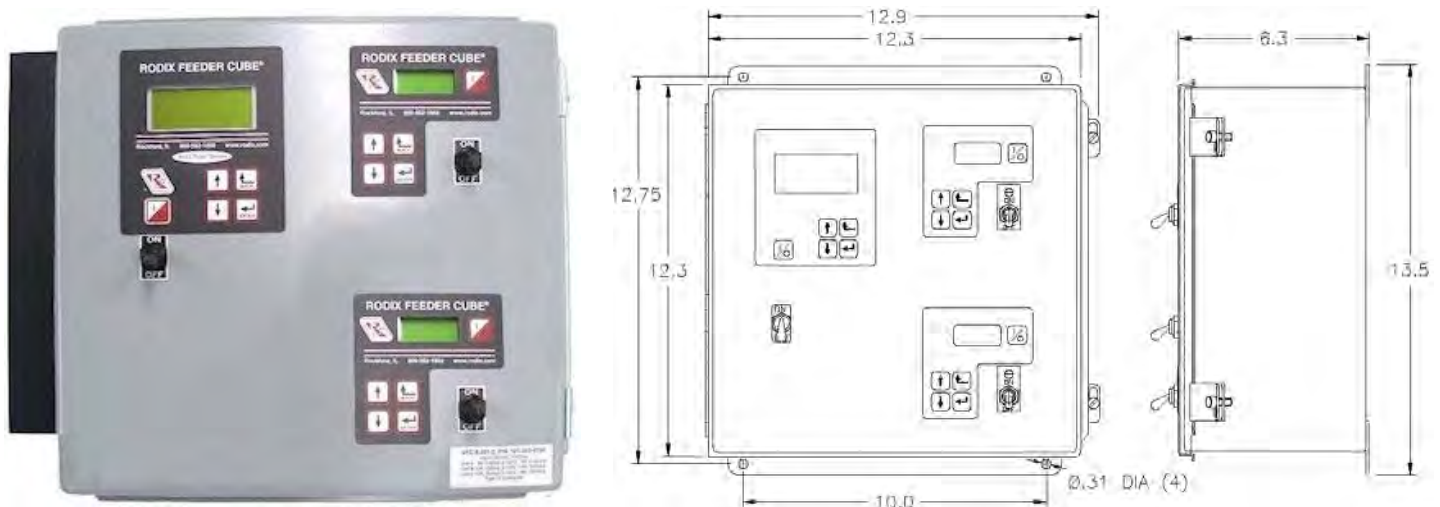

FC-200 CONTROL RUN JUMPER INPUT

A) LOW CURRENT SWITCH

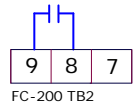

B) FEEDER BOWL/HOPPER INTERLOCK

FC-200/90 PLUS SERIES TB2, OUTPUT

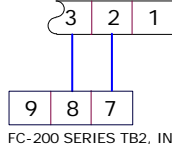

C) LOW VOLTAGE INPUT SWITCHING

(Remove Run Jumper and apply DC Voltage from PLC)

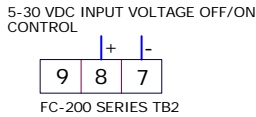

VF CONTROL RUN JUMPER INPUT

A) LOW CURRENT SWITCH

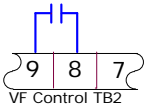

B) FEEDER BOWL/HOPPER INTERLOCK

Master VF Control TB2, OUTPUT

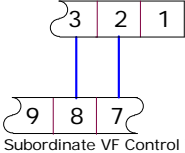

C) LOW VOLTAGE INPUT SWITCHING

(Remove Run Jumper and apply DC Voltage from PLC)

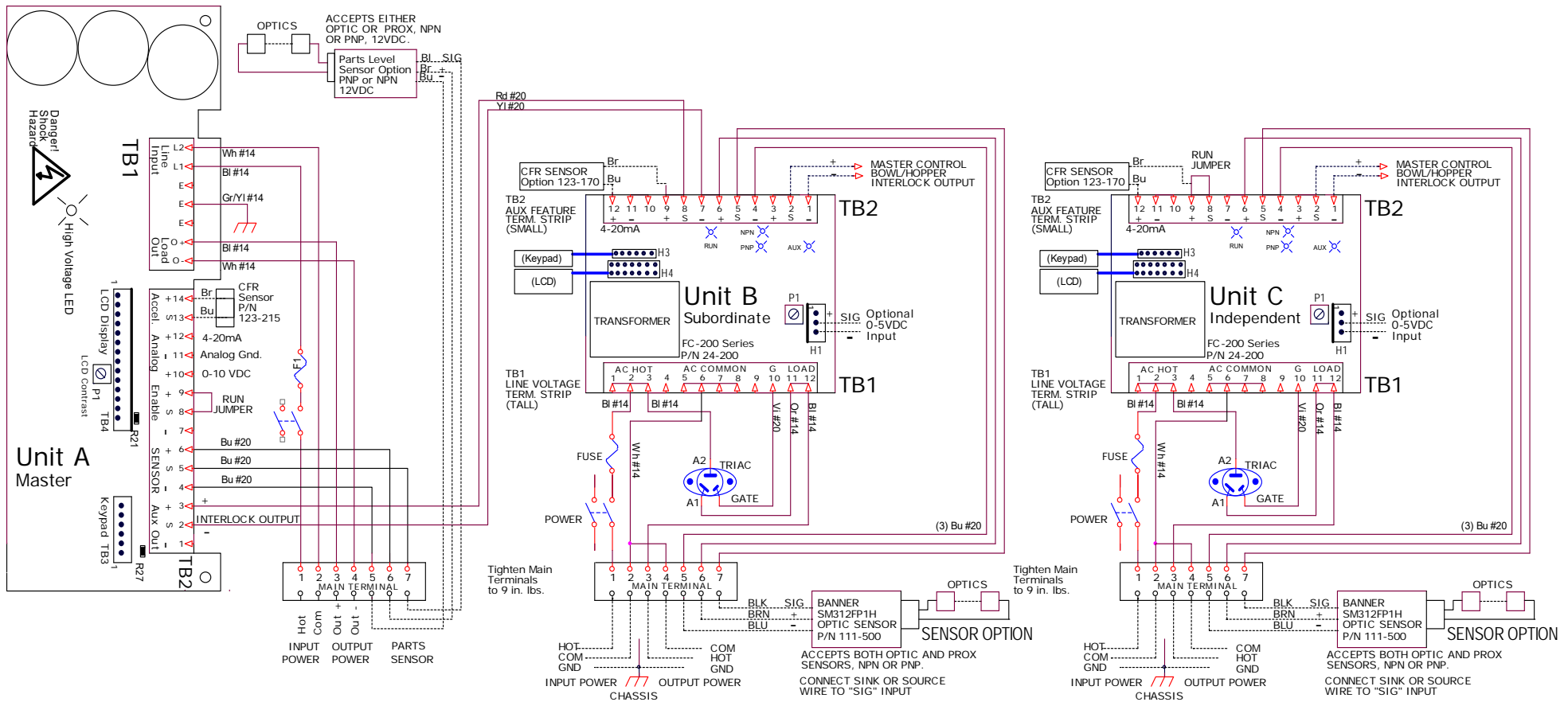
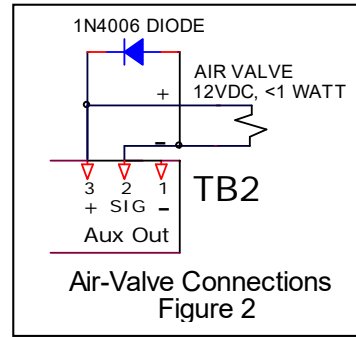
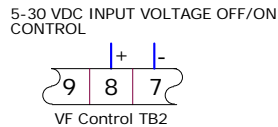

Figure 1



RODIX INC.
AUTO TUNE®
FEEDER CUBE®
VF Series

Auto Tune® Series of Variable Frequency controls

General Description

The Auto Tune® Series of variable frequency feeder controls are ideal for vibratory bowls, storage hoppers and linear inline feeders. The VF Series output frequency can be adjusted to match the natural frequency of the vibratory feeder. The amplitude sets the amount of vibration. The CFR vibration sensor allows the control to Auto Tune® to the optimum feeding frequency. The CFR sensor also regulates the vibration level. A feeder operating at its resonant frequency will perform efficiently using less power and provide better feeding performance.

Standard features include an easy to read backlit display, easy to understand status messages and simple to navigate set-up menu. Resonant frequency can be found manually using the keypad or automatically by mounting the optional vibration sensor, P/N 123-215, letting the controller scan the frequency range. The vibration sensor also provides feedback to help maintain a constant parts feed rate. Other features include a parts sensor input, an interlock output, enable input, soft-start adjustment, line voltage compensation, 4-20mA amplitude control, and lockable menu.

Control Sizing

A VF control should be sized according to the amperage needed to operate a full vibratory feeder. If the amps is unknown, use the following guidelines.

Most hoppers and linear inline feeders can be powered by a VF-3 control. Typical two coil feeder bowls can be driven by a VF-9 control. Two coil bowls with outside tooling that require a high feed rate should be connected to a VF-12 control. Three coil bowls should use a VF-12 control. Four coil bowls should use a VF-18 control.

© 2005, 2017 RODIX INC.

ADJUSTMENTS & SET UP

Mounting

The VF-3, VF-9 and VF-18 controls may be mounted vertically or horizontally, but the VF-3 and VF-9 controls stay cooler when mounted vertically. Mount the control to a metal plate or mount it so that the back of the heat sink is fully exposed to the air.

Important: The heat sink fins of the VF-12 power control must be mounted vertically with three inches of space above and below the heat sink for proper cooling.

The VF-18 control and heat sink are cooled by a fan. Mount the heat sink of the VF-18 control flat against a metal plate in order to ensure the fan's air flow through the heat sink.

Electrical Connections

Make the electrical connections prior to turning the control on. Once connections are made, any desired changes to the software settings can be made with the cover closed. **Warning: Shock Hazard! Do not operate control with cover open.**

Safety codes require single phase 120 or 240 VAC installations to bypass the phase 2 fuse, L2. To bypass, remove the wire connecting TB1-L2 to the L2 fuse holder. Remove the terminal end of the wire connecting the L2 fuse to the power switch and connect it to TB1-L2.

1. Parts Sensor Input

(Photo-sensor or Proximity Switch)

Connect a three wire, current-sourcing (PNP) or current-sinking (NPN) sensor to TB2 as shown on the enclosed wiring diagram. The sensor must be able to operate on 12VDC and be capable of switching at least 3.0 mA. See Parts Sensor Settings section for more operation information.

2. Run Input Enable

A Run Jumper comes installed from the factory as shown on the enclosed wiring diagram.

If the run input is to be controlled by a relay contact, switch, or other device, replace the factory-installed jumper (see TB2 of the wiring diagram) with the contact device. The contact must be able to switch 12VDC at 3.0 mA. The control will then run only

when the contact is closed and the part sensor is calling for parts. The right column of the display shows the run status with "R= 1" or "R= 0."

If the run input will be controlled by a current sourcing PLC output, use the "Sig" and "-" terminals (see TB2 on the wiring diagram).

For the High/Low parts sensing mode, a second parts sensor (PNP type only) connects to the run input in place of the run jumper.

3. Auxiliary Output

The right column of the display shows the status of the Aux output, "A=1" or "A=0." The Feeder Bowl/Hopper Interlock "+" and "sig" (see TB2 on the wiring diagram) can be connected to a Rodix FC-40 *Plus* All-Purpose Series control (TB2-11 & 12) when control of a bulk material hopper is needed. The control interlock will prevent the hopper from operating anytime the bowl is turned "OFF" or in "STAND BY" mode. The Interlock output is capable of switching 12 VDC at 85 mA. The Interlock output can also be used to drive a solid state relay that can operate auxiliary equipment such as air valves. See Figure 2 on the wiring diagram. One VF series control can be interlocked to another. The aux output of the master control connects to the run input of the subordinate. To monitor the AUX output with a PLC, see Figure 3.

A 1 Watt (or less) 12VDC air solenoid or a relay can be driven by the Aux output. Note: a diode (1N4006) must be placed across the solenoid in the reverse polarity to adsorb the energy when the solenoid is de-energized. The "bar" side of the diode connects to TB2 "+" and the "solid colored" side connects to TB2 "SIG." Failure to use a diode in reverse polarity voids the warranty.

4. Internal Power Supply

At the rated line voltage, the line isolated power supply is capable of providing a combined total current of 150 mA at 12 VDC. The total current includes the parts sensor, auxiliary output accessories, and CFR sensor.

5. Power Connections

The control can operate on a power line from 85 to 264VAC. The plug can be connected to a standard North American receptacle (NEMA 5-15R).

6/6/2017 Page 3

For 208 and 240VAC applications, cut the plug end(s) off and make proper plug-in connections for the factory's power lines.

The variable frequency control is energy efficient because it recaptures energy from the feeder coils every cycle. Because of the efficiency, the input power cord may be slimmer than the output cord. The VF-12 uses a #12 AWG output cord and the receptacle is not provided. The VF-18 uses a #10 AWG output cord and the receptacle is not provided.

6. External Speed Control Connections

The following methods of remote power level control can be utilized when desired:

- A. CFR sensor can maintain a constant feed rate. Attach the CFR sensor to terminals ACCEL “-“ (blue) and to ACCEL “+“ (brown). (Then update the software settings. Sections 11-A and 13-B)
- B. 4-20mA signal can be connected by bringing the positive signal wire to 4-20 “+“ and ground to 4-20 “-“. (Update software settings. Sect 11-B)
- C. 0-10VDC Analog input signal can be connected by bringing the positive signal wire to 0-10V “+“ and ground to 0-10 “-“. (Update the software settings. Section 11-C)

Software Adjustments

Once the electrical connections have been made, the control can be turned on. The software settings can be adjusted as desired through the control menu.

Display Messages

The normal operating display shows the status of the control with regard to input signals and control settings. See the Control Menu Layout page for display message details.

Navigating The Control Menu

The control uses four programming keys. The “I/O” key controls run, stop, and over-ride.

- A. The **ENTER** key allows entry to the menu and access to adjust each setting. Push and hold the enter key to enter the program mode. If the security feature has been enabled, enter the proper code. Once inside the menu, the enter key selects a menu item or a parameter to adjust. Any changes to the settings are saved at power-down.
- B. The **BACK** key moves the current menu location up one level higher than it was before. It is also used to get back to the normal operating display.
- C. The **Arrow Down** key allows the user to step down through the program menu or to decrease a

setting.

- D. The **Arrow Up** key allows the user to step up through the program menu or to increase a setting.
- E. The “**1/0**” key allows the user to temporarily stop or to start the control's operation. When the LCD status reads “Stop/Run,” hold the “1/0” key down for just over a second, and the control will start the over-ride operation. In over-ride mode the output turns on regardless of I/O connections and status. See the “Control Menu Layout” chart for the menu structure. When in the menu mode and no keys are pressed for 1 minute, the display reverts to the normal operating display mode.

7. Amplitude Power Setting

The output power is controlled by the up and down arrow keys. The power setting can be adjusted with the keys unless the security feature lock has been selected. Once the proper security code has been entered, the power setting may be adjusted under the “Power” menu. Note: the power setting may not be above the maximum power setting or below the minimum power setting level. The amplitude power setting is displayed in the following manner:
A = 50.0%.”

8. Limiting The Maximum Output Of Control

The “Max Amplitude” setting can be adjusted to keep a vibratory feeder from hammering or vibrating excessively when the control is turned up to full power. The maximum power setting can be found under the “Power” menu. It can be adjusted from 100.0% down to 40.0%.

Caution: it is recommended when using the CFR feature, that the Max output level of the control should be limited to prevent feeder coil from overheating. The amplitude could continue to increase if the system cannot get back to the desired vibration level.

9. Setting The Minimum Output of Control

The “Min Amplitude” setting can be adjusted to the desired low level of vibration. The minimum power setting can be found under the “Power” menu. It can be adjusted up from 0.0% to 95.0%. Note: the software does not allow the minimum level to be within 5.0 counts of the maximum level.

10. Setting The Soft-Start

The start-up of the control's output can be adjusted to ramp up to the desired output level instead of starting abruptly. Soft-start keeps parts from falling

off the tooling, reduces spring shock, and can eliminate hammering when the control turns ON. The soft start setting can be found under “Power Settings” menu. The soft start can be set from 0.0 to 10.0 seconds. When using the 2 speed operation, the soft start function is active during the low to high speed transition.

11. External Speed & Frequency Control

The feeder control's power level can be controlled by an external signal from a PLC, CFR sensor, or an analog source. The “External Speed Connections” section gives connection details.

- A. When the Constant Feed Rate (CFR) sensor is used, set “Amplitude Source” and “Frequency Mode” to “Auto Track.” The control should display “Run/CFR” showing that the sensor is connected. Set the power setting to the desired feed rate. The control uses information from the CFR sensor to maintain a constant vibration level at the resonate frequency. See the CFR instructions page for more information.

The CFR Set Point can be adjusted remotely by a 4-20mA PLC signal. The control's amplitude will regulate to the vibration level of the CFR Set Point value. Set the Amplitude Source to Auto Tracking.

Caution: it is recommended when using the CFR feature, that the Max output level of the control should be limited to prevent the feeder coil from overheating. The amplitude could continue to increase if the system cannot get back to the desired vibration level.

- B. 4-20mA signal from a PLC can be used to remotely vary the output of the control instead of the keypad. The “Amplitude Source” setting must be set to 4-20mA to enable it. After the 4-20mA feature is selected, the control will automatically turn ON whenever a 4-20mA signal is applied to the control (TB2 “+ 4-20” & “-“). When the 4-20mA signal has been removed, the amplitude setting resets to zero.

The 4-20mA menu selection allows a PLC to control both the output Frequency and Amplitude or only the Frequency or just the Amplitude. The amplitude is controlled by the 4-20mA input. The Frequency is controlled by the 0-10VDC signal. The signal adjusts a 100Hz range.

The Min Frequency adjustment specifies the frequency used when the 0-10VDC input is at 0VDC. The Max Frequency adjustment can be used to ignore the upper end of the 0-10VDC signal.

- C. 0-10VDC signal from a PLC can be used to remotely vary the output of the control instead of the keypad. The "Amplitude Source" setting must be set to 0-10VDC to enable it. After the 0-10VDC feature is selected, the control will automatically turn ON whenever a signal is applied to the control (TB2- "+0-10" & "-"). When the 0-10VDC signal has been removed, the amplitude setting resets to zero.
- D. When it is desirable to ignore the external speed control inputs, the "Manual" setting can be selected.

12. CFR Positive and Negative Gain

The CFR Positive and Negative Gain settings control the rate the feeder's vibration level is corrected by the control. When the vibration decreases below the set-point, the "CFR Positive Gain" sets the rate at which the output gets boosted to compensate for a vibration decrease. When the vibration increases, the "CFR Negative Gain" sets the rate at which the output gets lowered to compensate for a vibration increase. If either the CFR Positive or Negative gain is set too low, it will take longer than desired to get back to the original feed rate. If either gain is set too high, the control may over-shoot beyond the original feed rate. The CFR Positive and Negative Gain settings effect the control's operation when the CFR sensor is used, and the "Amplitude Control" is set to "Auto Track."

13. Frequency Settings

The "Frequency" menu contains the portion of the menu that controls the frequency settings. The frequency can be adjusted from 5 to 140Hz (or 300Hz on VF-3 and VF-9 controls). The spring/mass ratio of the vibratory bowl determines the natural vibrating (resonate) frequency of the bowl. The control's output frequency needs to be adjusted to match the natural frequency of the bowl. The control can be manually tuned or automatically tuned. The frequency setting is displayed as "F= 120.0Hz." The "Frequency Mode" setting selects either manual frequency adjustment or auto tracking frequency adjustment.

- A. Manually finding the resonate frequency of the

bowl is much like finding a station on the AM radio band. Set the amplitude to about 30%. Then adjust the frequency across its range. The bowl should be expected to vibrate the parts at more than one spot across the frequency range. The resonate frequency is the frequency with the most vibration. Once the best feeding frequency range has been found, fine tune the frequency for the best parts movement. To increase feeder stability for parts load fluctuations, adjust the frequency down by .2 or .3Hz so that the feeder becomes slightly over-tuned.

- B. "Auto Scan" scans to locate the bowl's resonate frequency. Once auto tracking has found the resonate frequency, it can maintain the resonate frequency and amplitude of the feeder as the parts load changes. The CFR sensor is needed in order for auto tracking to operate, and "Auto Tracking" needs to be turned on under both "Amplitude Source" and "Frequency Mode" menus. To show when frequency "Auto Tracking is enabled, the normal display menu will show a bold "F." When "=" is shown in bold, the control is locked onto the resonate frequency of the feeder.
- C. The frequency can be adjusted with an analog 0-10 volt input when the amplitude source setting is set to 4-20mA.

The Minimum frequency limit can protect the feeder from feeding at a low frequency if a spring or weld breaks. The Min. or Max. frequency can block out undesirable frequencies during Auto Scan. To avoid coil damage and blown fuses during an Auto Tune scan, the Minimum frequency should only be adjusted below the 45Hz default when the vibratory feeder has been specifically designed for operation below 45Hz.

14. Resonate Threshold Level

The "Resonate Threshold Level" setting sets the minimum level of vibration that the control considers as a resonate condition during an Autoscan. The setting should be reduced if a "Coarse Scan Error" is given after two scan attempts. Adjustment is not normally needed except for some inlines.

15. Auto Track Dead Band

The "Auto Track Dead Band" setting controls how far the resonant frequency of the vibratory feeder can deviate before the output frequency of the control is adjusted to follow it. Decreasing the setting narrows the range, and increasing the setting makes the dead

band range larger before a reaction takes place. This setting normally doesn't need to be changed.

16. Setting The Time Delays

The ON and OFF parts-sensor time-delays are set independently for a period of 0-20 seconds. The time delay settings can be adjusted to provide the best individual response for the feeder. The time delays can be found under the timer settings menu. The flashing "=" blinks every quarter second to show when either the ON or OFF delay timer is running.

17. Parts Sensor Settings

The "I/O Interface" menu contains the portion of the menu that controls the parts sensor type and polarity.

- A. The control comes preset to AUTO to work with either an NPN or PNP sensor. If the sensor input status "S=1 or 0" indicates the input is on all of the time, set the control to either NPN or PNP to match the type of sensor being used.
- B. The control comes preset to "inverted" sensor polarity. Set the sensor polarity to either "Normal" (through beam) or "Inverted" (proximity or retro-reflective).

18. Run Mode Settings

The "I/O Interface" menu contains the portion of the menu that controls the run mode and empty bowl logic.

- A. The control comes preset for normal on/off parts sensor operation. The following can be chosen:
 - 1) The "Constant On" feature can be used to keep the bowl running while the Aux output switches power to a device (air valve, SSR, or relay).
 - 2) The "2-Speed" feature allows the bowl to keep some vibration going to either trickle parts for weigh counting or to cut down the time to full speed when a high feed rate is needed. The parts sensor switches between high and low speed settings. Low speed is set by "Min Amplitude."
 - 3) The "high/low" function maintains the parts level between two parts sensors on the track. The second sensor (PNP) gets installed in place of the run jumper.
- B. The control comes preset with the "empty bowl timer" (or parts jam timer) disabled. Once enabled, the bowl will stop feeding when parts have not passed the sensor for the set time. The empty bowl timer can be adjusted from 5 to 255

seconds under the “timer settings” menu. Press the “1/0” key or toggle the parts sensor to restart the control. The auxiliary output can be set up to turn on a signaling device. See the section that describes the auxiliary output for more details.

19. Auxiliary Output Settings

The “Aux Output Mode” menu contains the menu that controls the auxiliary output (Aux Out) operation.

- A. The factory-default “Normal” setting allows the auxiliary output to turn on and off with the output of the feeder.
- B. The auxiliary output can be set to have its signal inverted from the output of the feeder. Set the “Aux Out” parameter to “Invert” to activate it.
- C. The auxiliary output can be set so that the alarm signal can indicate when the “Empty Bowl” timer has timed out. Set the “Aux Out” parameter to “Alarm” to activate it.
- D. The auxiliary output can be set so that the alarm signal can be inverted when the “Empty Bowl” timer has timed out. Set the “Aux Out” parameter to “Inv Al” to activate it.
- E. The auxiliary output can be set so that an air solenoid can be activated 1 second before feeding begins and continue for 4 seconds after feeding ends. This feature is helpful for parts orientation. Set the “Aux Out” parameter to “Air Jet” to activate this feature.

20. Diagnostics

- A. The first menu item under the diagnostic menu shows the software revision level.
- B. The next four items under the software revision level show certain software registers that may be helpful to Rodix staff while troubleshooting over the phone.

21. Security Settings

The “Security” menu contains the portion of the menu that controls access to the program menu settings. When enabled, the security code is a number from 000 to 999. The preset code is 123. It may be changed.

- A. The control comes with the security setting “Unlocked” so the control can be set up. The amplitude can be adjusted from the normal operating display. Press and hold “Enter” to enter the program menu and adjust the software settings.
- B. The amplitude only (Ampl. Only) adjustment allows operators to adjust the amplitude through the normal operating display, but not get to the program menu settings without the security code.

- C. The “Lock” setting locks the control from any adjustment without the use of the security code. If the security code has been forgotten, enter the security code #010, **press and hold** “Enter” until entry has been granted. Note: ignore the “Wrong Security Code” message. Once in the programming menu be sure to set the security code.

22. Default Memory

Occasionally it is nice to get back to a known setting. Once a feed system has been set up properly, the setting should be manually saved into the “Save Settings1” memory. If an operator disturbs the settings, the “Restore Settings1” feature can restore the control to a known good set up. When different parts are used on the same feed system, two other memory locations called “Save Setting2” and “Save Settings3” can be used for other parts. Operators can recall settings 1, 2 or 3 based on the part being used. The “Factory Reset” selection will put the original factory settings into the memory.

23. Language

The run display and programming menus can be set to display in English, Spanish (Español), French (Français), or German (Deutsch).

24. Over Current Protection

The control has a coarse over-current fault protection that trips when the output is above the rated current shown in the chart below. Under certain load conditions the VF-12 & VF-18 controls will supply less current when operating below 16 Hz.

	Rating with 120V input	Rating with 240V input	120V Rating below 16Hz
VF3	3 Amps	1.5 Amps	N/A
VF9	9 Amps	4.5 Amps	N/A
VF12	12 Amps	6 Amps	8 Amps
VF18	18 Amps	9 Amps	14 Amps

The operator should monitor the output current to ensure that it is within the desired range. If an “Over Current” occurs, press the “1/0” key to restart the control. The operator should also monitor the temperature of the coils on the vibratory feeder. The coils should never be too hot to hold by hand.

25. CFR Set Point

The CFR set point sets the amplitude vibration level that the control regulates to. The VF Series control adjusts the amplitude automatically to match the

CFR set point. The CFR set point can be adjusted by the depression of the “UP” and “DOWN” arrows keys. Holding an arrow key down will adjust the amplitude setting instead of the CFR set point. The CFR set point can also be controlled by a 4-20mA signal.

The CFR set point only appears on the display when the “Amplitude Source” menu under power settings is set to “Auto Track” and the CFR sensor is attached.

26. Fault Messages

The VF control has error and warning messages that relate to “Over-Amps”, “Over-Temp” and Bowl out of parts timers. To clear the message or fault, press the “1/0” button twice. “Coarse and Fine Scan Error” mean not enough vibration was measured during an Autoscan. Reduce Resonate Threshold.

WARNING:

Fuses should be replaced with Littelfuse 3AB “Fast Acting” type or equivalent of manufacturer's original value.

Mounting this control on a vibrating surface will void the warranty.

Warranty

Rodix Control Products are Warranted to be free from defects in material and workmanship under normal use for a period of two years from date of shipment. For the full description of the warranty, terms, and software license, please contact the factory.

For assistance installing or operating your Rodix Feeder Cube® please call the factory or visit our web site. Technical help is available to answer your questions and email any needed information. To return a control for IN or OUT of warranty service, please ship it prepaid to:

Rodix Inc., ATTN: Repair Department

If under warranty, Rodix will repair or replace your control at no charge; If out of warranty, we will repair it and you will be billed for the repair charges (Time and Material) plus the return freight. Quotes for repairs are available upon request. A brief note describing the symptoms helps our technicians address the issue.

Feeder Cube® and Auto Tune® are registered TM of Rodix Inc. Banner® is a registered Trademark of Banner Engineering Corp, 9714 10th Ave, Minneapolis, MN 55441

RODIX, INC.

2316 23rd Avenue, Rockford, IL 61104

Toll Free (800) 562-1868

E-mail custserve@rodix.com

www.rodix.com

Steps to Interlock Two VF Series Controls together

If a PLC is interfaced to both controls, optical isolation is necessary, see step 4 below.

1. Remove the run jumper from TB2 terminals 8 & 9 of the subordinate control.
2. Add a wire from terminal 3 of the master control to terminal 8 of the subordinate control.
3. Add a wire from terminal 2 of the master control to terminal 7 of the subordinate control.
4. If optical isolation between the controls is desirable, remove R21 from the subordinate control.

VF Series Master Control

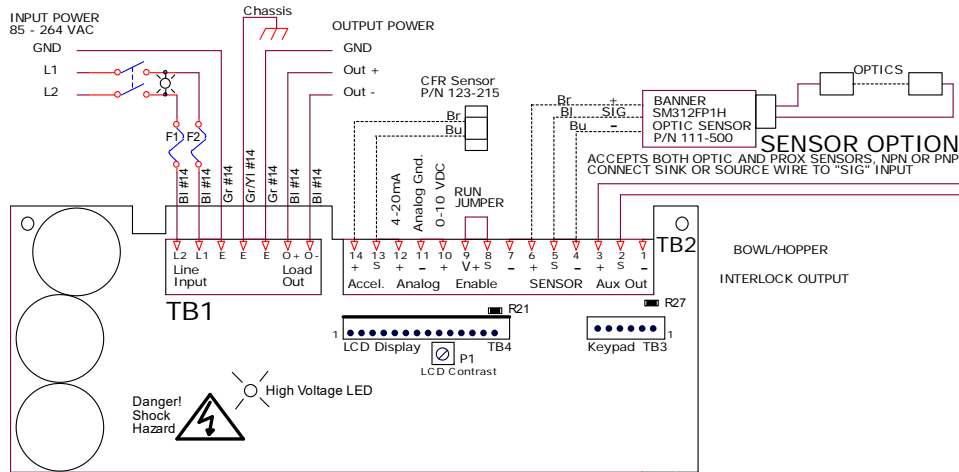

VF Series Subordinate Control

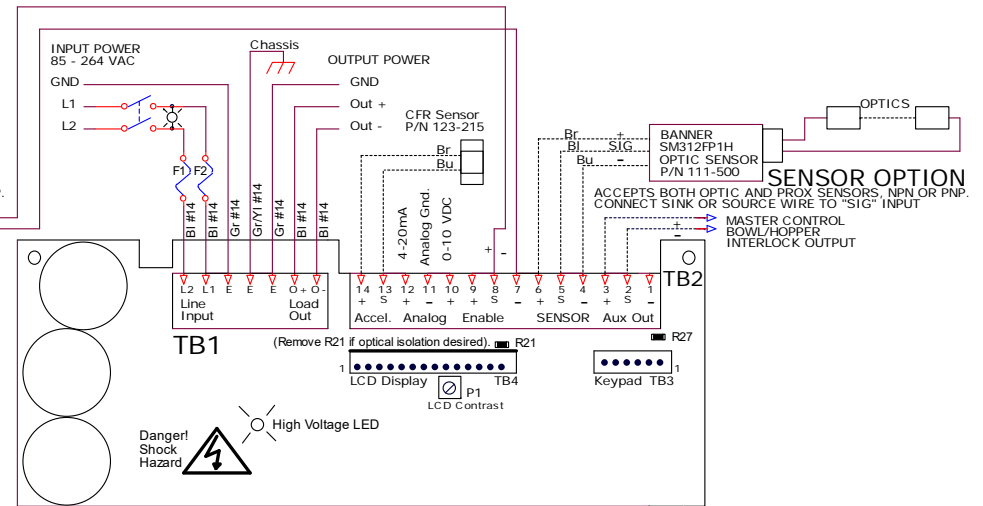

Steps to Interlock an FC-40 Plus Series to a VF Series Control

1. Add a wire from terminal 2 of the VF master control to TB2-11 of the subordinate control.
2. Add a wire from terminal 3 of the VF master control to TB2-12 of the subordinate control.
3. Move the run jumper on the subordinate control from TB2-6 & TB2-7 to TB2-5 & TB2-6.

VF Series Master Control

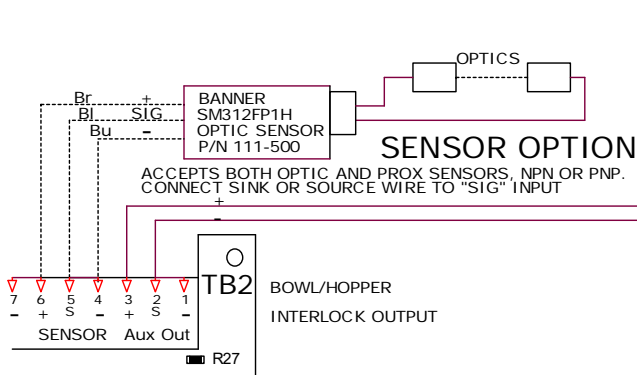

FC-40 Plus Subordinate Control

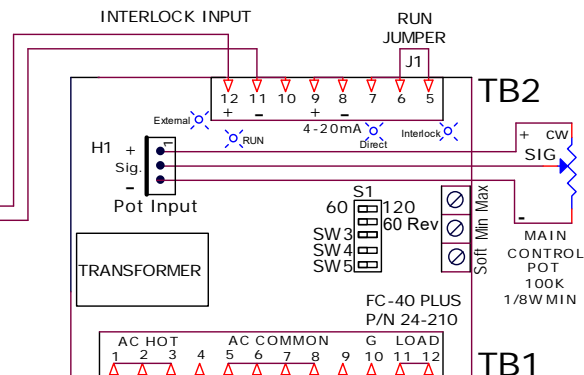

Steps to Monitor the AUX Output with a PLC

Configure the AUX output to source current from an external power supply to the PLC.

- 1) Connect the power supply +24 VDC to TB2-2.
- 2) Connect TB2-1 to the PLC input.
- 3) Connect the power supply common to the PLC common.

Note: If the PLC or power supply has any other connection to the PCB, then R27 must be removed. Use pliers to twist and snap off R27. R27 is located behind TB2-1.

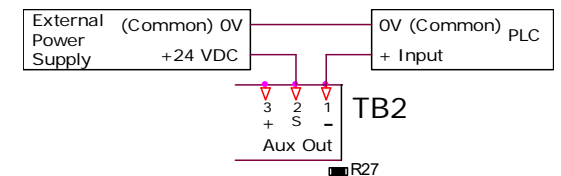

PLC Monitor of reconfigured Auxiliary Output
Figure 3

Control Menu Layout for VF-3, VF-9

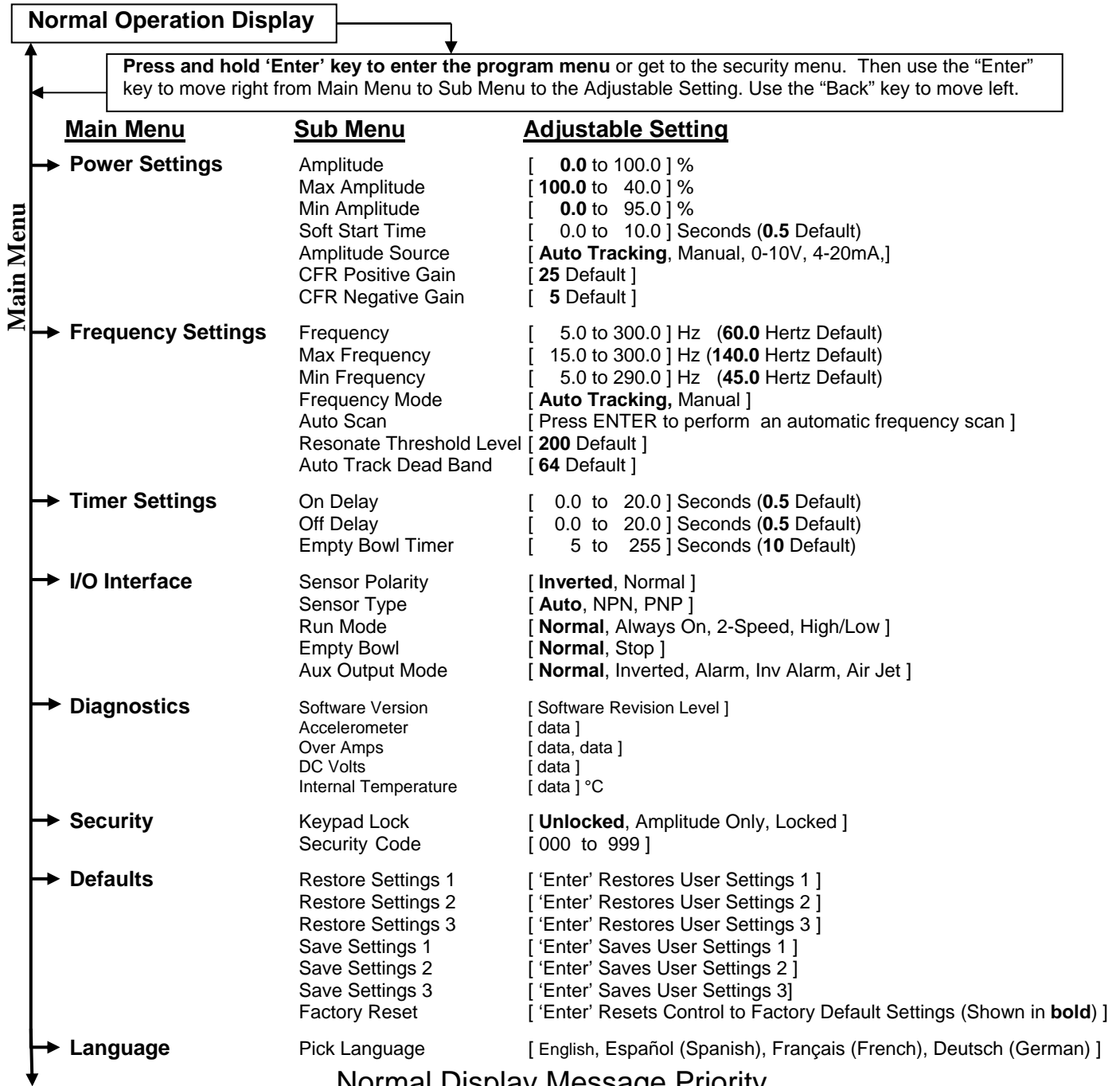

Normal Display Message Priority

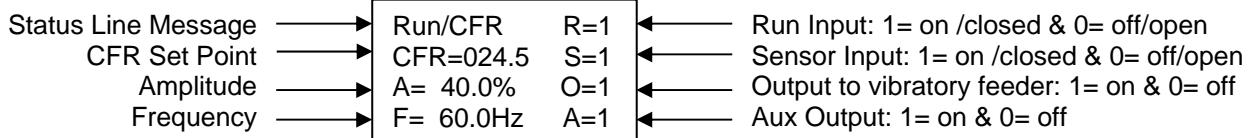

The normal operating display shows the status of the control with regard to input signals and control settings. They are listed from highest to lowest in priority. The highest priority message takes precedence over the other messages.

Stop/Run - The 1/0 button has been pushed to disable control operation.

Override - The 1/0 button has been pushed and held so the control feeds while ignoring the "Sensor" or "Run" inputs.

Run Input - The run jumper has not been made.

Parts Sens - The parts sensor and control logic is telling the control to stay off.

Empty/jam - Empty bowl timer has timed out because parts did not pass by the parts sensor to reset the timer. Press 1/0

Analog - An external signal is in control of the speed input.

Low - Low Speed used when 2 speed has been selected and the sensor is not made.

Zero Speed - The output is off because the output is set to 0.0%.

Run - The feeder is running normally.

Run/CFR - Constant Feed Rate sensor is regulating the feed rate (Autotune®).



INSTALLING THE CFR SENSOR

Note: Failure to adequately prepare the feeder's surface properly may result in a Constant Feed Rate (CFR) sensor that will not bond to the feeder. The sensor should not be mounted until step C-6.

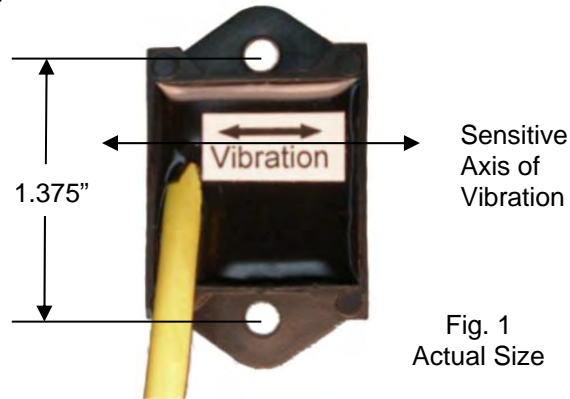

Fig. 1
Actual Size

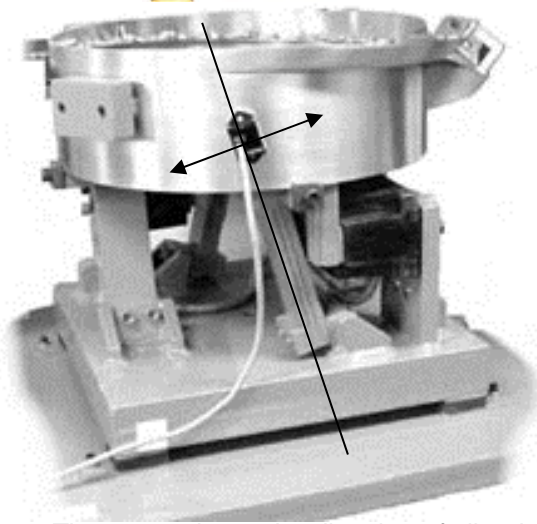

Fig. 2 The arrow shows the direction of vibration which is at a right angle to the spring pack.

A. ORIENT THE SENSOR so that its sensitive axis is in the same direction as the vibration of the feeder. The double-ended arrow in figure 1 shows

the sensor's sensitive axis. Align the sensitive axis of the sensor in the same direction as the vibration (see figure 2). The sensor must be oriented correctly for proper operation.

B. CHOOSE A LOCATION for mounting the sensor on the feeder that is smooth and that will allow the adhesive on the sensor to bond. Avoid mounting the sensor over ridges and bumps which can reduce the ability of the adhesive to stick to the feeder. The correct location will also have enough space for the sensor's cable to hang straight down without touching anything else.

C. SURFACE PREPARATION of the feeder is crucial for proper bonding between the sensor and the feeder. Please follow these steps completely.

- 1) The feeder should be kept between 70° and 100° F for ideal tape application.
- 2) Clean a three and one-half inch circular area with a solvent like isopropyl alcohol that will not leave a residue. As a rule of thumb, the area can be considered clean when after cleaning the area with a solvent-saturated, white paper-towel, the towel is as clean as it was before wiping.
- 3) Using a good amount of pressure, polish the cleaned, circular area of the feeder using a scratch pad or steel wool. Repeat step 2, and then go to step 4.
- 4) Wipe the cleaned surface with an alcohol wipe or with a 50/50 isopropyl alcohol/water combination.
- 5) Dry the surface thoroughly using a low lint cloth or a clean paper towel.
- 6) Remove the vibration sensor from its protective backing. Remove the liner from the adhesive backing. Avoid touching the tape. Align the sensor as shown in figures 1 and 2. Apply the vibration sensor to the prepared area of the feeder. Press the sensor very firmly onto the feeder surface for at least 10 seconds.
- 7) Allow the vibration sensor at least 20 minutes to cure before operation. Note: It takes 72 hours for the adhesive to fully cure at 70° F.

Alternatively, #8 or M4 screws can be used to mount the sensor to the feeder. The mounting holes are 1.375" (3.49cm) apart.

D. ROUTE THE SENSOR CABLE to protect it from strain due to vibration. The cable that attaches to the sensor will not break from normal vibration; however, some care should be used when routing the sensor cable from the sensor to the control. The cable should hang straight down from the sensor without touching

the feeder bowl or anything else. Then, the sensor cable should curve towards the power control with a bend radius larger than 3 inches.

Use a cable tie and an adhesive-backed mount to attach the sensor cable to the side of the drive base. See Figure 2. Clean the mounting area before applying the adhesive-backed mount.

E. CONNECT THE SENSOR to the control. If needed, connect the sensor cable's brown wire to "+ACCEL" on TB2. The blue wire connects to the "-ACCEL" on TB2.

F. SELECT THE SENSOR in the software settings of the control menu. See the Control Menu Layout page for a visual layout of the program menu.

- 1) Press and hold the "Enter" key to enter the main menu.
- 2) With "Power Settings" displayed, press the "Enter" key to get into the submenu.
- 3) Arrow "Down" to select the "Amplitude Source" submenu.
- 4) Press the "Enter" key, and Arrow "UP" to select "Auto Tracking" from the adjustments.
- 5) Press the "Back" key twice to get back to the main menu.
- 6) Next, arrow "Down" to the "Frequency Settings" selection.
- 7) Press the "Enter" key to get into the submenu.
- 8) Arrow "Down" to select the "Frequency Mode" submenu.
- 9) Press the "Enter" key, and Arrow "UP" to select "Auto Tracking" from the adjustments.
- 10) Press the "Back" key three times to get back to the normal running display.

G. PERFORM AUTO SCAN of the vibratory feeder. See the Control Menu Layout page for a visual layout of the program menu.

- 1) Press and hold the "Enter" key to enter the main menu.
- 2) Arrow "Down" to select the "Frequency" submenu.
- 3) Press the "Enter" key, and Arrow "UP" three times to select "Auto Scan" from the adjustments.
- 4) Press the "Enter" key to perform an automatic frequency scan.

RODIX, INC.
Toll Free (800) 562-1868
E-mail custserve@rodix.com
www.rodix.com



FC-200 Series Application Note
 For Circuit Boards P/N's
 24-200 (120V) and 24-201 (208-240V)

General Description

The FC-200 Series Controls are often used to operate vibratory bowls equipped with part sensors or storage hoppers fitted with electronic bowl level detectors. The 12VDC power supply and sensor time delays are provided by the control. The demand cycling of the bowl is controlled by the parts sensor's output and the control's On and Off time delay settings.

Standard features include an interlock output, enable input, soft start adjustment, minimum and maximum output adjustments, full wave/half wave selection, line voltage compensation, 4-20mA and 0-5vdc amplitude control. The optional CFR vibration sensor, P/N 123-170, can provide feedback to help maintain a constant part feed rate.

The FC-200 Series Feeder Cube® is a completely digital feeder control. All of the set up and adjustments are performed through the keypad on the front cover. With an easy to read LCD display, the feed rate, sensor status, and control status are easily observed.

ADJUSTMENTS & SET UP

ELECTRICAL CONNECTIONS:

Make the electrical connections prior to plugging the control in and turning it on. Once connections are made to the feeder control, any desired software settings changes can be made with the cover closed.

1. PARTS SENSOR

(Photo-sensor or Proximity Switch)
 Connect a three wire, current-sourcing (PNP) or current-sinking (NPN) sensor as shown on the enclosed wiring diagram. The sensor must be able to operate on 12VDC and switch 3mA. The default setting is a universal sensor input.

2. RUN JUMPER INPUT

The Run Jumper Input comes with a factory installed jumper wire. If the Feeder Cube® will be controlled by a relay contact, switch, or other device, replace the factory-installed jumper with a "Run Contact" at terminals 8 and 9 of TB2. The contact will switch 12VDC and 2.0 mA. The control will run only when the contact is closed and the parts sensor is calling for parts. For PLC control, remove the Run Jumper and connect the 24V PLC output to TB-2 terminals 8 (+) and 7 (-). If electrical isolation is desired, remove R3. R3 is located on the circuit board near TB2-8.

In the High/Low parts sensing mode, a second parts sensor can be connected to the run contact input in place of the run jumper. Each parts sensor should be a PNP type and have the same logic (L.O. or D.O.).

3. AUXILIARY OUTPUT

The Feeder Bowl/Hopper Interlock feature (TB2-1 & 2) can be connected to a Rodix FC-40, FC-90, FC-200 or VF Series control when control of a bulk material hopper is needed. The interlock will prevent the hopper from operating anytime the bowl is turned OFF or in "STAND BY" mode. The Auxiliary Interlock output can also be used to drive a solid state relay or a low wattage 12VDC air valve. A solid state relay can operate any auxiliary equipment such as a light stand or an air valve. To monitor the Auxiliary Output with a PLC see the details in the Advanced FC-200 Application Note. The Interlock output is capable of 12 VDC at 50 mA. The Auxiliary output is capable of

switching 70 mA if an external power source is used. Two FC-200 Series controls can be interlocked. Download the FC-200-2 Application Note for wiring information.

A 0.6 Watt 12VDC solenoid can be driven by the Aux output. See the wiring diagram for proper connections.

4. INTERNAL POWER SUPPLY

At the rated line voltage, the line isolated power supply is capable of providing a combined total current of 65 mA at 12 VDC (35 mA when using a 200VAC line on 240VAC models). The total current includes the parts sensor, CFR sensor and any auxiliary output accessories that are connected to the Bowl/Hopper Interlock terminals.

5. REMOTE SPEED CONTROL CONNECTIONS

The following methods of remote power level control can be utilized when desired:

- A. The Constant Feed Rate (CFR) feature: Attach a CFR sensor to terminals TB2-12 (blue) and to TB2-9 (brown).
- B. 4-20mA or 0-20mA signal can be connected by bringing the positive signal wire to TB2-12 and ground to TB2-11.
- C. 0-5VDC Analog input signal can be connected to connector H1. This can be selected to ignore any connections to the CFR/4-20mA input. Control cable P/N 123-145 is sold separately.

Section 14 explains how to enable these features.

6. OUTPUT CONNECTIONS

The 120VAC models in general purpose enclosures provide a standard North American receptacle (NEMA 5-15R) for connection to the feeder. 240V models have a pigtail output cord. Power cords are optional on Oil Resistant models.

7. LINE VOLTAGE CONNECTIONS

The 120VAC models can operate from a power line providing from 108 to 132VAC. The plug can be connected to a standard North American outlet. The outlet should be properly grounded. The 240VAC models can operate from 200 to 265VAC. The control should be grounded properly.

SOFTWARE ADJUSTMENTS:

DISPLAY MESSAGES: The normal operating display shows the status of the control with regard to input signals and control settings. See the “Menu Layout” page for message details.

SOFTWARE ADJUSTMENTS: Once the electrical connections have been made, the control settings can be adjusted as desired through the control’s menu.

NAVIGATING THE CONTROL MENU: The control uses four keys to program the control. The fifth key, “1/0” is for on/off operation.

- A. The **ENTER** key allows entry to the menu and access to adjust each setting. Pushing the enter key once allows entry to program or the security code if the security feature has been enabled. Once inside the menu, the enter key selects a menu item or a parameter to adjust.
- B. The **BACK** key moves the current menu location a level higher than it was before. It is also used to get back to the normal operating display.
- C. The **Arrow Down** key allows the user to step down through the program menu or to decrease a setting.
- D. The **Arrow Up** key allows the user to step up through the program menu or to increase a setting.
- E. The **1/0** key allows the user to temporarily stop or restart the control’s operation.

See the “Menu Layout” page for the menu structure. When in the menu mode and no keys are pressed for 1 minute, the display reverts to the normal operating display.

8. PARTS SENSOR SET UP

Set up the parts sensor through the “Function Settings” sensor logic and sensor output type menu.

- A. The “NORMAL” setting works with most PNP and NPN sensors. If the sensor input does not seem to switch, set the sensor type to PNP or NPN to match the sensor type. The sensor input status can be monitored on the LCD; S=0 or 1.
- B. The control comes preset to work with inverted sensor logic. Set control for the type of sensor logic being used: “Normal” for through beam optics or “Inverted” for proximity or retro-reflective optics.

9. POWER OUTPUT SETTING

The output power is controlled by the UP and DOWN arrow keys. The power setting can be adjusted

unless the security feature lock has been selected. Once the proper security code has been entered, the power may be adjusted under the “Power Settings” menu. Note: the power setting may not be adjusted above the maximum power setting or below the minimum power setting level. The max and min power settings automatically change the power setting to keep it in the correct range.

10. PULSE MODE OPERATION

The “Power Settings” menu controls the pulse mode settings. The pulse mode can be set for 120, 60, 60-reverse, 40 or 30 pulses. The correct pulse setting depends on what the feeder was tuned to operate at.

- A. 120 pulses per second is the default setting.
- B. 60 pulses per second (half wave) can be selected from the pulse settings menu.
- C. 60 reverse indicates the opposite side of the half wave sin wave is used). This can be helpful for two different situations. When a changing the amplitude on one feeder influences the amplitude of the second feeder, reversing the 60 pulse output sometimes may solve a mechanical interaction between two feeders on the same machine table. Secondly, the apparent power from the utility can be reduced if the power can be balanced when some feeders are set to 60 pulse and some are set to 60 reverse pulse. To activate it, set the pulse mode to “60 Rev.”
- D. 40 or 30 Pulse can be selected in the pulse mode menu. For useful vibration, the feeder has to have the proper amount of springs.

11. LIMITING MAXIMUM POWER

The maximum power (Max Pwr) setting can be lowered to keep the operators from setting the vibration higher than desired. The maximum power setting can be found under the “Power Settings” menu. It can be adjusted from 100.0% down to 40.0%.

12. MINIMUM POWER OUTPUT

The minimum power (Min Pwr) output level can be adjusted to the desired low level of vibration. The minimum power setting can be found under the “Power” menu. It can be adjusted up from 0.0% to 60.0%. Note: the software does not allow the minimum level to be within 6.4 counts of the maximum level.

13. SOFT-START

The start-up of the control’s output can be adjusted to ramp up to the desired output level instead of starting abruptly. Soft-start keeps parts from falling off the tooling, reduces spring shock and hammering when the control turns ON. The soft start setting can be found under “Power” menu. The soft start can be set from 0.0 to 10.0 seconds.

14. REMOTE SPEED CONTROL

The feeder control’s power level can be controlled by an external signal from a PLC or other source. Selections are made under the “Power Settings” menu. See section 5 for connection details.

- A. The Constant Feed Rate (CFR) feature comes preset in the control. Attach a CFR sensor to terminals TB2-12 (blue) and to TB2-9 (brown). Turn the power switch on, and the control should display “CFR” in the status line showing that it is connected. Set the power setting to the desired feed rate. **The CFR set point can also be set remotely by applying a 0-5VDC signal to connector H1.** Purchase cable P/N 123-145.
- B. A 4-20mA or 0-20mA signal from a PLC can be used to remotely vary the output of the control instead of the keypad. Once selected, the control will automatically turn ON whenever a signal is applied (terminals 11 & 12 of TB2). At 0mA the keypad may be used. The 0-20/4-20mA input is transformer isolated from the power line.
- C. 0-5VDC Analog input signal can control the feeder’s amplitude. Use cable P/N 123-145.

15. SETTING THE TIME DELAYS

The ON and OFF sensor time delays are set independently for a period of 0-25 seconds. The time delay settings can be adjusted to provide the best individual response for the feeder. The time delays can be found under the “Timer Settings” menu.

16. LINE VOLTAGE COMPENSATION

Fluctuations in the line voltage can cause a feeder bowl to vary its feed rate. The line voltage compensation feature adjusts the control’s output to help compensate for fluctuations in the supply voltage. If it becomes necessary to disable this feature, the LV Comp setting can be changed to “Disable”. It is found under “Power Settings” menu.

17. RUN MODE SETTINGS

The “Function Settings” menu controls the feed logic.

- A. The control comes preset for normal on/off sensor operation.
- B. The “Constant On” feature can be used to keep the bowl running while the Aux output switches a device (air valve) to blow the unneeded parts back into the bowl.
- C. The “2-Speed” feature allows the bowl to slowly trickle parts on low speed and to feed parts at full speed when the sensor signals parts are needed.
- D. The “high/low” function keeps the parts level between the high and low parts sensors on the track. The second sensor (PNP) gets installed in place of the run jumper.
- E. The Run Input can be set to “Disable” to ignore the interlock signal from another control board. Changes to the interlock wiring are not needed.
- F. The Empty Bowl Timer feature is used to turn the feeder off when no parts have broken the sensor field from the settable range of 5 - 240 seconds. The feature’s default setting is off, but it can be activated under the “Timer Settings” menu. An auxiliary output can be set up to activate a signaling device such as a light stand or strobe light when the empty bowl timer is tripped. See section 18 for auxiliary output set up instructions.

18. AUXILIARY OUTPUT SET UP

The “Function Settings” menu controls the auxiliary output (Aux Out) operation.

- A. The control comes preset for the auxiliary output to turn on and off with the output of the feeder.
- B. The auxiliary output signal can be inverted from the output of the feeder. Set the “Aux Out” parameter to “Invert” for an inverted output signal.
- C. The auxiliary output signal can be set as an alarm to indicate when the bowl out-of-parts timer has stopped the feeding of the bowl. Set the “Aux Out” parameter to “Alarm” to activate it.
- D. The auxiliary output signal can be set to invert the alarm when the bowl out-of-parts timer has stopped the feeding of the bowl. Set the Aux Out parameter to “Inv Al” to activate it.
- E. The auxiliary output signal can be set so that a customer supplied air solenoid is activated 1 second before feeding begins and continue for 4 seconds after feeding ends. This feature is helpful for parts orientation. Set the “Aux Out” parameter to “Air Jet” to activate this feature.

19. DIAGNOSTICS

- A. The first menu item under the “Diagnose Info” menu shows the software revision level.
- B. The next item under the software revision level shows certain software registers that may be helpful to Rodix staff while troubleshooting.

20. SECURITY SETTINGS

The “Security Settings” menu controls access to the control settings. When enabled, a security code number may be chosen from 00 to 255. The preset code is 00.

- A. The “Unlock” setting allows menu access to all control adjustments and features.
 - B. The amplitude only (Amp Adj) adjustment allows operators to adjust the amplitude through the normal operating display. All other settings can only be adjusted after entering the security code.
 - C. The “Lock” setting locks the control from any adjustment without the use of the security code.
- If the security code has been forgotten, press the enter key to bring up the security code. Next, push and hold the back key until the menu appears. This sequence bypasses the security code.

21. DEFAULT MEMORY

Once a feed system has been set up properly, the Feeder Cube’s set-up should be saved into the “User Save” memory location. If an operator makes wrong adjustments, the “Restore User” feature can restore the control to the known good set up. The restore factory defaults selection will put the original factory settings into memory.

22. LANGUAGE

The programming menus can be displayed in English, Spanish (Español), French, German (Deutz).

23. INSTALLING THE CFR SENSOR

Note: Failure to adequately prepare the feeder’s surface properly may result in a Constant Feed Rate (CFR) sensor that will not bond to the feeder. The sensor will not be mounted until step C-6.

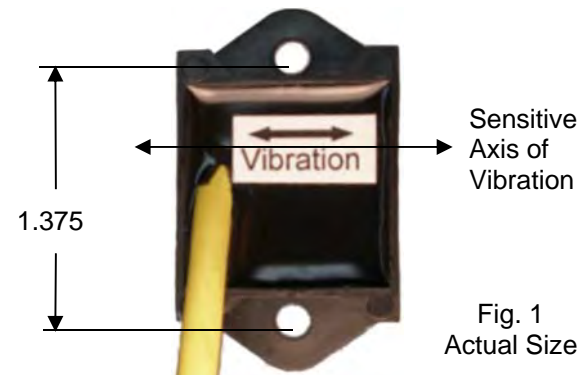

Fig. 1
Actual Size

A. ORIENT THE SENSOR so that its sensitive axis is in the same direction as the vibration of the feeder. The arrow in figure 1 shows the sensor’s sensitive axis. Align the sensitive axis of the sensor in the same direction as the vibration (see figure 2). The sensor must be oriented correctly for proper operation.

B. CHOOSE A LOCATION for mounting the sensor on the feeder that is smooth and that will allow the adhesive on the sensor to bond. Avoid mounting the sensor over ridges and bumps which can reduce the ability of the adhesive to stick to the feeder. The correct location will also have enough space for the sensor’s cable to hang straight down without touching anything else.

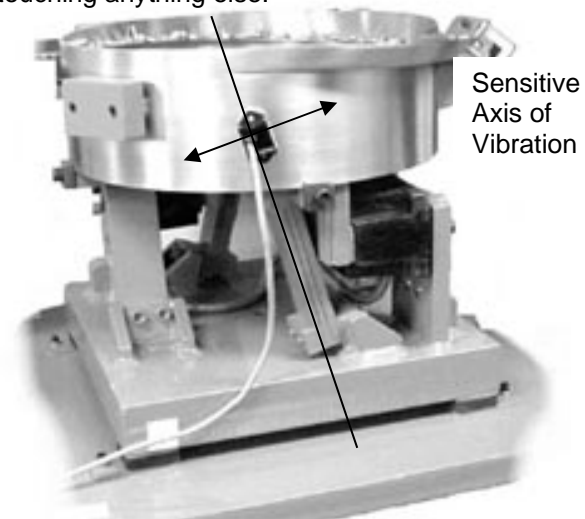

Fig. 2 The arrow shows the direction of vibration which is at a right angle to the spring pack.

C. SURFACE PREPARATION of the feeder is crucial for proper bonding between the sensor and the feeder. Please follow these steps completely.

- 1) The feeder should be kept between 70°-100°F (21-38°C) for ideal tape application.
- 2) Clean a 3.5" (10cm) circular area with a solvent like isopropyl alcohol that will not leave a residue. As a rule of thumb, the area can be considered clean when after cleaning the area with a solvent-saturated, white paper-towel, the towel is as clean as it was before wiping.
- 3) Using a good amount of pressure, polish the cleaned, circular area of the feeder using a scratch pad or steel wool. Repeat step 2, and then go to step 4.
- 4) Wipe the cleaned surface with an alcohol wipe or with a 50/50 isopropyl alcohol/water combination.
- 5) Dry the surface thoroughly using a low lint cloth or a clean paper towel.
- 6) Remove the vibration sensor from its protective packaging. Remove the liner from the adhesive backing. Avoid touching the tape. Align the sensor as shown in figures 1 and 2. Apply the vibration sensor to the prepared area of the feeder. Press the sensor very firmly onto the feeder surface for at least 10 seconds.
- 7) Allow the vibration sensor at least 20 minutes to cure before operation. Note it takes 72 hours for the adhesive to fully cure at 70°F (21°C).

Alternatively, #8 or M4 screws can be used to mount the sensor to the feeder. The hole centers are 1.375" (3.49cm) apart.

D. ROUTE THE SENSOR CABLE to protect it from strain due to vibration. The cable that attaches to the sensor will not break from normal vibration; however, some care should be used when routing the sensor cable from the sensor to the control. The cable should hang straight down from the sensor without touching the feeder bowl or anything else. Then, the sensor cable should curve towards the power control with a bend radius larger than 3" (8cm).

Use a cable tie and an adhesive-backed mount to attach the sensor cable to the side of the drive base. See Figure 2. Clean the mounting area before applying the adhesive-backed mount.

E. CONNECT THE SENSOR to the control. The sensor's brown wire connects to +12VDC at TB2-9. The blue wire connects to the signal input at TB2-12.

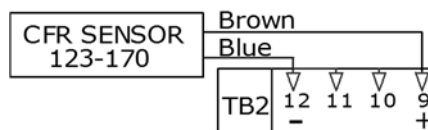

F. Section 14 explains how to enable the CFR feature.

24. CFR Positive and Negative Gains

The rate of response to vibration-changes can be adjusted using the Positive and Negative Gain settings. Oscillations can be reduced by lowering the CFR positive and negative gains or detuning the feeder slightly by adding or removing a spring.

25. CFR Set Point Adjustment

The CFR set point adjusts the amplitude vibration level that the control regulates to. The CFR Set Point changes when the amplitude of the control is adjusted. For better repeatability, the CFR set point can be precisely adjusted in the Power Settings menu.

The CFR set-point can be adjusted by a PLC. Connect the PLC to the 0-5VDC Analog input and verify the "Ext Sig" sub menu selection is set to CFR mode. Purchase cable 123-145.

26. Troubleshooting

If the feeder is not running, the status line on the LCD displays the reason the control is not feeding. The status line displays the highest priority message. The status line message definitions can be found on the FC-200 Series Menu Layout page under the section titled "Normal Display Message Priority".

The LED's on the circuit board show the status of the Run, PNP, NPN inputs and the Aux output. The wiring diagram references the location of the LEDs on the circuit board. The "Run" LED must be lit and the sensor type and logic must be set properly for the control to operate. If no parts sensor is connected, set the sensor logic setting to "Invert". If the sensor appears to work, but the control's display does not

register a change in sensor status (S=1 or 0), set the sensor type to PNP or NPN so it matches the sensor's output type. If the feeder only hums, change the pulse mode setting.

For more troubleshooting helps, download the FC-200 Troubleshooting Guide at www.rodix.com.

WARNING:

Fuses should be replaced with Bussman ABC or Littelfuse 3AB "Fast Acting" type or equivalent of manufacturer's original value.

Mounting this control on a vibrating surface will void the warranty.

WARRANTY

Rodix Control Products are Warranted to be free from defects in material and workmanship under normal use for a period of two years from date of shipment. For the full description of the warranty, terms, and software license, please contact the factory.

For assistance installing or operating your Rodix Feeder Cube® please call the factory or visit our web site. Technical help is available to answer your questions and email any needed information. To return a control for IN or OUT of warranty service, please ship it prepaid to:

Rodix Inc., ATTN: Repair Department

If under warranty, Rodix will repair or replace your control at no charge; If out of warranty, we will repair it and you will be billed for the repair charges (Time and Material) plus the return freight. Quotes for repairs are available upon request. A brief note describing the symptoms helps our technicians address the issue.

Feeder Cube® is a registered TM of Rodix Inc.

Banner® is a registered Trademark of Banner Engineering Corp, 9714 10th Ave, Minneapolis, MN 55441

RODIX, INC.

2316 23rd Ave., Rockford, IL 61104
Toll Free (800) 562-1868, FAX (815) 316-4701
E-mail custserve@rodix.com
rodix.com

FC-200 Series Menu Layout

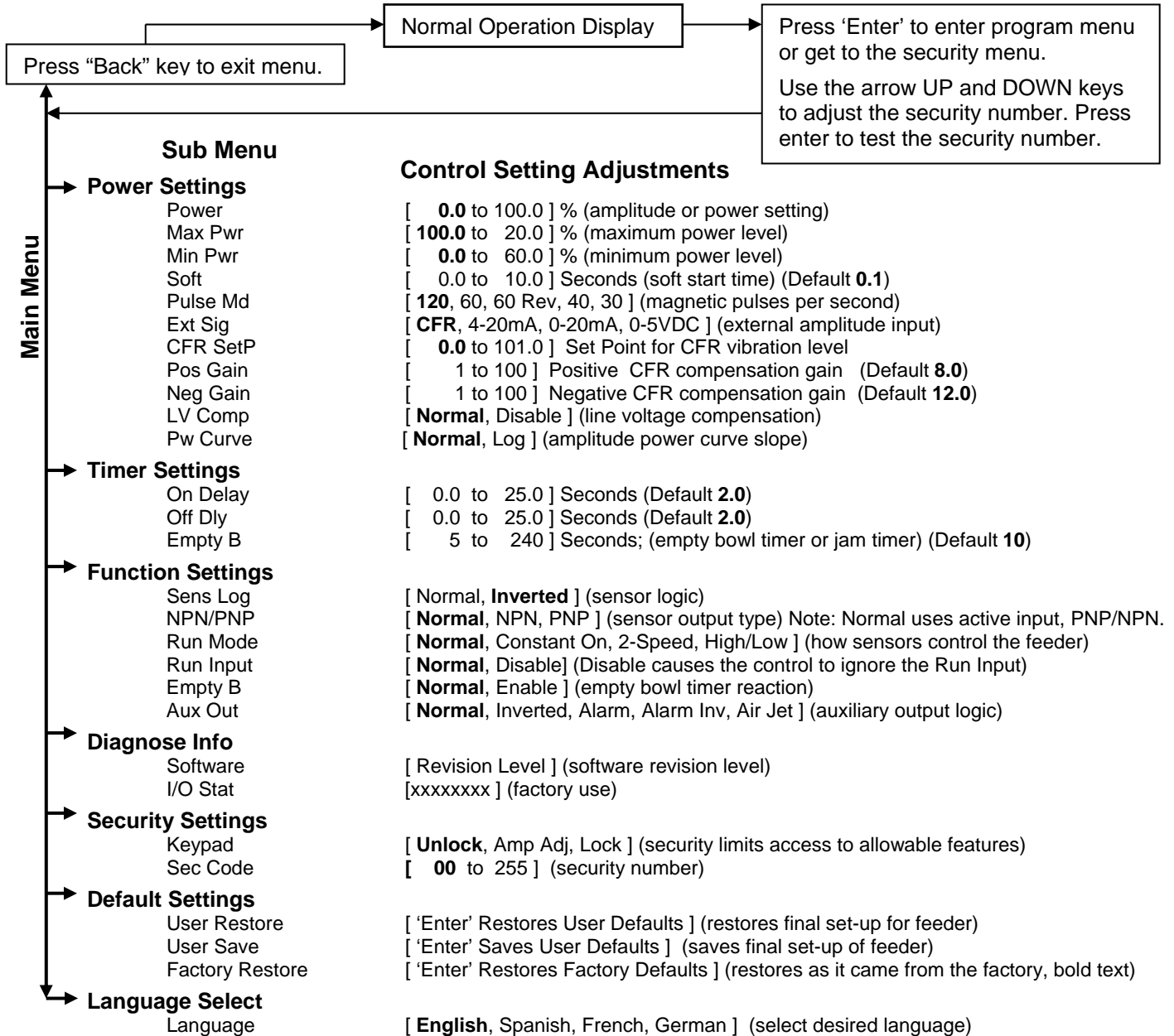

Normal Display Message Priority

The normal operating display shows the status of the control with regard to input signals and control settings. They are listed from highest to lowest in priority. The highest priority message takes precedence over all other messages.

- OFF** The 1/0 button has been pushed to disable control operation.
- Stop** The run jumper has not been not made.
- Full** The parts sensor logic is telling the control to stay off.
- Empt** Empty bowl timer has timed out because parts did not pass by the parts sensor for a certain time.
- Ext.** An external signal is in control of the speed input.
- Low** Low Speed used when 2 speed has been selected and the sensor is not made.
- 0Spd** The output is off because the output is set to 0.0%.
- CFR** The CFR function is operating, and the feeder is running normally.
- Run** The feeder is running normally.

Sensor Status Messages

- S=1** The parts sensor indicates parts are needed.
- S=0** The parts sensor indicates parts are not needed.
- =** The Flashing equal sign indicates the parts sensor is timing prior to changing the output state.

Power Setting Messages

- Mn** Mn indicates the power setting is at the minimum amplitude.
- Mx** Mx indicates the power setting is at the maximum amplitude.



RODIX SOLUTION

Good wiring practices for avoiding electrical noise problems.

Rodix controls have been designed with a high degree of immunity to electrical noise; however, depending on the control installation, electrical noise can cause problems. These problems occur in less than 1% of the product installations. Most electrical noise problems can be avoided by following some simple guidelines. Good wiring practices need to be used to prevent electrical noise from interfering with your control's operation. Another name for electrical noise is Electro-Magnetic Interference (EMI).

Symptoms of Electrical Noise

The symptoms of electrical noise would appear as follows: a brief pause or a brief "bump" in the vibratory feeder's output that the control automatically recovers from. In rare cases the control will either stop operating or run continuously at full power in 120 pulse mode until the power switch is slowly cycled OFF and ON.

Sources of Electrical Noise

Electrical noise is generated by devices like relay coils, solenoid valves, contactors, servo motors, and variable

frequency inverter drives. The electrical noise is then transferred to another device by one of three ways. The noise could be conducted through the power wires, or capacitively coupled from wire to adjacent wire, or it is transmitted from the wires of a nearby noise source.

Solutions for Electrical Noise

1. Use shielded wires for all I/O (Input / Output) signals. The I/O signals may include: 4-20mA input, Run input, Sensor input, 0-5VDC input, Interlock input or AUX output. The shield "drain" wire should be tied to the chassis in the Rodix control. The drain wire should be kept shorter than 2". Please see the enclosed picture.

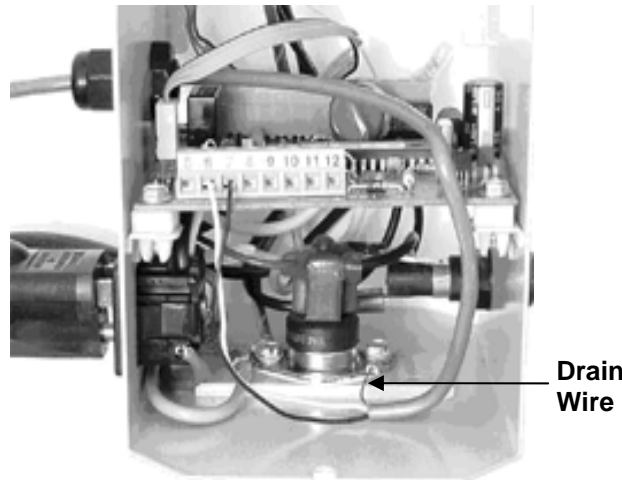

Example of a "drain" wire termination

2. Never run I/O signal wires in the same conduit or raceway as AC power lines such as wires to motors, solenoids, heaters, welders and Rodix controls, etc.

3. I/O wires within an enclosure should be routed as far away as possible from relays, solenoids, transformers, power wiring and other noisy equipment. Keep the I/O signal wires separate from the control's input and output power wiring. Secure the wires in place.

4. Whenever relays or solenoid valves are used, install a Snubber on them to reduce electrical noise. Use a diode on a DC coil. Use a RC Snubber on an AC coil.

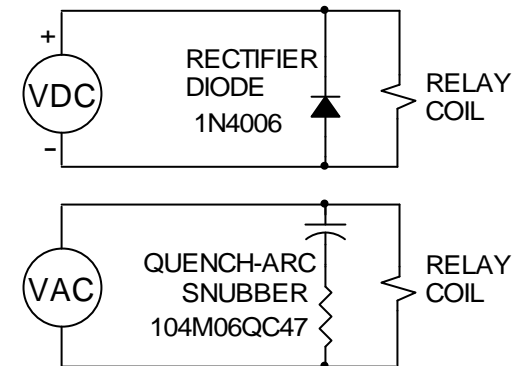

5. In extremely high EMI environments, Power Line Filters and ferrite beads can be effective. Install ferrite beads on I/O signal wires as close as possible to the circuit board terminal strip. Loop the wire through the bead several times or use several beads on each wire for additional protection.

RODIX, INC.

Toll Free (800) 562-1868

E-mail custserve@rodix.com

www.rodix.com