



**RODIX INC.**  
**FEEDER CUBE®**  
**FC-200 Series**  
**ADVANCED**  
**FEATURES**

## Optional Wiring Configurations for the 24-200 / 24-201 circuit boards

### OVERVIEW

The **FC-200 Series** of feeder controls is built around circuit boards 24-200 (120VAC) and 24-201 (230VAC). The input voltage tolerance for the 24-200 board is 90-120VAC (or 115V +/- 10%). The input voltage tolerance for the 24-201 board is 180-240VAC (or 230V +/- 10%). Note: vibratory feeders may not feed well at low line conditions. Each board contains two power supplies, phase-angle firing control for the triac, a Sensor input, a "Run" input, one or two speed inputs, one auxiliary output, and logic circuitry to perform on-delays and off-delays. A LCD and keypad interface to each circuit board.

### POWER SUPPLY

The 12VDC power supply is available for external use having a maximum current capacity of 65mA (35 mA when using a low line voltage of 100VAC or 200VAC). The power supply is transformer isolated from the utility power.

When connecting an External 24VDC power supply to TB2, the 12V power supply won't be damaged on Rev. G or higher PCB's. If desired, the power supply can be isolated from TB2 by removing the 0 Ohm SMT resistors described in the ISOLATION section of this document.

### 0-5VDC, 4-20mA, 0-20mA ANALOG INPUTS

The **FC-200 Series** feeder control has a **0-5VDC** analog signal input and a **4-20mA / 0-20mA** analog signal input for controlling the vibration level of the feeder bowl. These features can be enabled within the "Ext Sig" portion of the Power Settings menu.

A **4-20mA** or **0-20mA** analog input is the second type of input signal that can control the output vibration level. This method has a better signal to noise ratio than the 0-5VDC input control. Connect the mA signal to TB2-11 (GND) and TB2-12 (SIG) to allow the feeder's vibration level to be adjusted remotely.

Whenever the 4-20mA input current is above 4mA (or the 0-20mA is above 0mA), the 4-20mA signal controls the vibration level. When the 4-20mA signal is active, the keypad control is automatically disabled, and the keypad amplitude is set to zero. When the mA input current is at 0mA, control of the vibration level goes back to the keypad control.

### Application Hints:

For Local/Remote control of the vibration level, use a switch to toggle between the mA signal and the keypad control of the amplitude value. The switch interrupts the mA current at TB2-12.

**0-5VDC input:** Either a 0-5VDC or a potentiometer input signal can be used to control the output level of the control.

A **0-5VDC** signal can be applied to H1, the analog input instead of using the Main pot. See figure below. To improve noise immunity, do not connect a wire to the unneeded pin of connector H1.

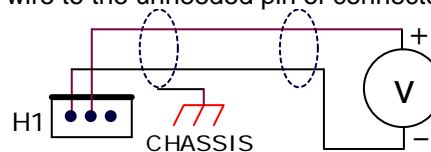

0-5VDC Input Diagram

A **0-10VDC** signal can be applied to the analog input by using a voltage divider circuit to scale the input voltage to 0-5VDC. See figure below.

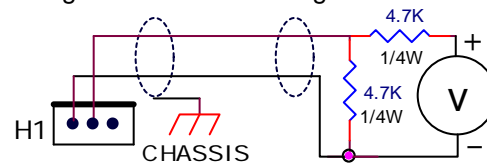

0-10VDC Input Diagram

The optional H1 cable, P/N 123-145 may be used anytime a remote signal or a remote pot is used. The shield of the "H1" cable should be tied to chassis ground at the Rodix end of the cable.

Remote pot operation can be achieved by using a 3-wire shielded cable connected to H1, the analog input. The shield (drain wire) should be connected to the chassis ground only at the Rodix control end of the cable. See the wiring diagram for pot wiring connections.

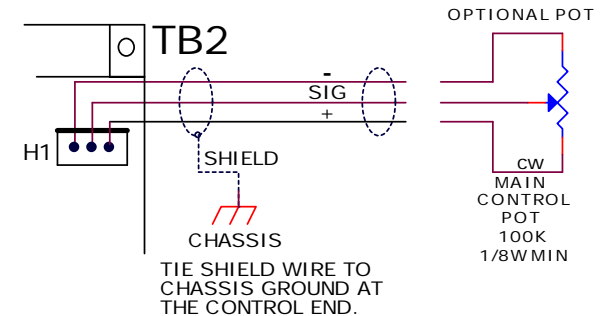

**RODIX, INC.**  
Toll Free (800) 562-1868  
E-mail [custserve@rodix.com](mailto:custserve@rodix.com)  
FAX (815) 316-4701  
[rodix.com](http://rodix.com)

## RUN INPUT

Remote OFF/ON control normally can be accomplished by using a dry relay contact at terminals TB2-8 and TB2-9. When a contact is unavailable, one of the following can be used.

A PLC having a PNP (current sourcing) output can provide remote OFF/ON control to the control's Run input. Connect the PLC's PNP output (Pos 5-30VDC) to TB2-8. Connect the PLC's ground to TB2-7. Apply the signal whenever the control should be enabled. Electrical isolation of the Run Input is optional. Remove resistor R3 near TB2 from the FC-200 Series circuit board when isolation is desirable. Use pliers to twist and snap off resistor.

A PLC having an NPN (current sinking) output can provide remote OFF/ON control to the control's Run input. Connect the PLC's NPN output (-) to TB2-7. Connect the PLC's power supply (Pos 5-30VDC) to TB2-8. Apply the signal whenever the control should be enabled. Electrical isolation of the Run Input is optional. Remove resistor R3 from the FC-200 Series circuit board when isolation is desirable. Use pliers to twist and snap off resistor.

## AUXILIARY OUTPUT

The auxiliary output is useful for controlling other feeder controls, solid-state relays, small DC solenoids, and PLC inputs. Normally the auxiliary (interlock) output turns ON whenever the control output is ON.

The AUX output comes from the factory configured to source current from the internal power supply: see the "typical relay wiring" drawing. The AUX output can source current from the internal power supply which is rated at 85mA or from an external power supply.

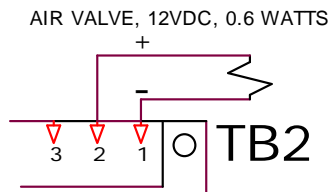

Typical relay or air valve wiring.

To monitor the AUX output with a PLC, configure the AUX output to source current from an external power supply to the PLC. Connect the power supply +24VDC to TB2-3. Connect TB2-2 to the PLC input. Connect the power supply common to the PLC common.

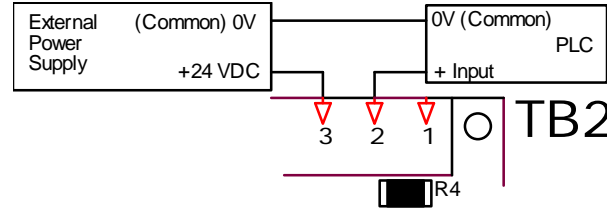

Auxiliary Output configured for PLC monitoring

Removing R4 & D8 optically isolates the internal power supply from anything connected to TB2-2 & TB2-3. The AUX output is capable of switching 80mA at 24VDC when an external power supply is used.

If the PLC (typically A-B) can monitor a 11 VDC signal (as a high level), then the 24VDC wiring is unnecessary. Instead, connect TB2-2 to the PLC + input and connect TB2-1 to the PLC common. Note: TB2-1 is connected to the internal power supply and is transformer isolated from the power line.

Terminals TB2-1&2 on Rev J (or higher) PCB's are protected from the counter EMF produced by a relay or solenoid. It is not necessary to install a diode across a relay or solenoid coil.

## SENSOR INPUT

The sensor input is designed for a three wire, current-sourcing (PNP) or current-sinking (NPN) sensor. The sensor must be able to operate on 12VDC. In the Function Settings menu select PNP or NPN according to the sensor's output type.

The sensor input can be monitored with a PLC if the sensor is powered by an external 24VDC power supply provided by the customer.

## MINIMUM AMPS

The feeder control is designed to operate with a minimum load of 0.6 amps.

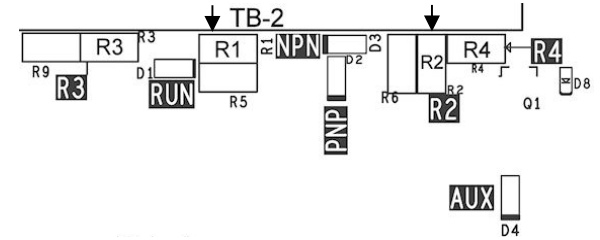

## ISOLATION

The FC-200 Series control is transformer isolated from the line, the isolation is rated at 2500V. The chassis to ground isolation is 1000V. The sensor input, run input, analog (pot) input and auxiliary output all share the same power supply common.

The sensor input can be optically isolated if parts R1 and R2 are removed from the circuit board. The sensor power must then be supplied from an external 5-30VDC source. The run input can be optically isolated by removing resistor R3 from the circuit board. The Auxiliary output at terminals TB2-2&3 can be optically isolated by removing resistor R4 and diode D8 from the circuit board. Caution: Do not remove D8 if a relay or solenoid is connected to TB2-1&2. Note: TB2-1 is always connected to the internal power supply common. Please read all directions before removing parts. Use pliers to twist and snap off parts.

## NOISE IMMUNITY

For further details about noise immunity, see the Feeder Cube® application note for your model and refer to the page titled Good Wiring Practices for Avoiding Electrical Noise Problems.

For electrically noisy (high EMI field) environments, it is recommended that shielded signal wires be used if the wire length is over 2 meters. Ground the drain wire of the shield at the control end of the cable. Keep the shield drain wire less than 2 inches in length.

## Technical Support

Application notes, troubleshooting guides, and Rodix solution guides are available at [www.rodix.com](http://www.rodix.com).

CFR "-", 12

CFR "+", 9

AUX OUTPUT USED TO INTERLOCK ANOTHER CONTROLLER OR TO DRIVE AUXILIARY EQUIP.

A RUN JUMPER IS USUALLY INSTALLED AT TERMINALS 8 & 9

USE 3 WIRE PNP or NPN SENSOR

TO SOURCE CURRENT USE: 2 (SIG) & 1(-)  
TO SINK CURRENT, REMOVE R4  
USE: 3 (SINK) & 2 (COM)

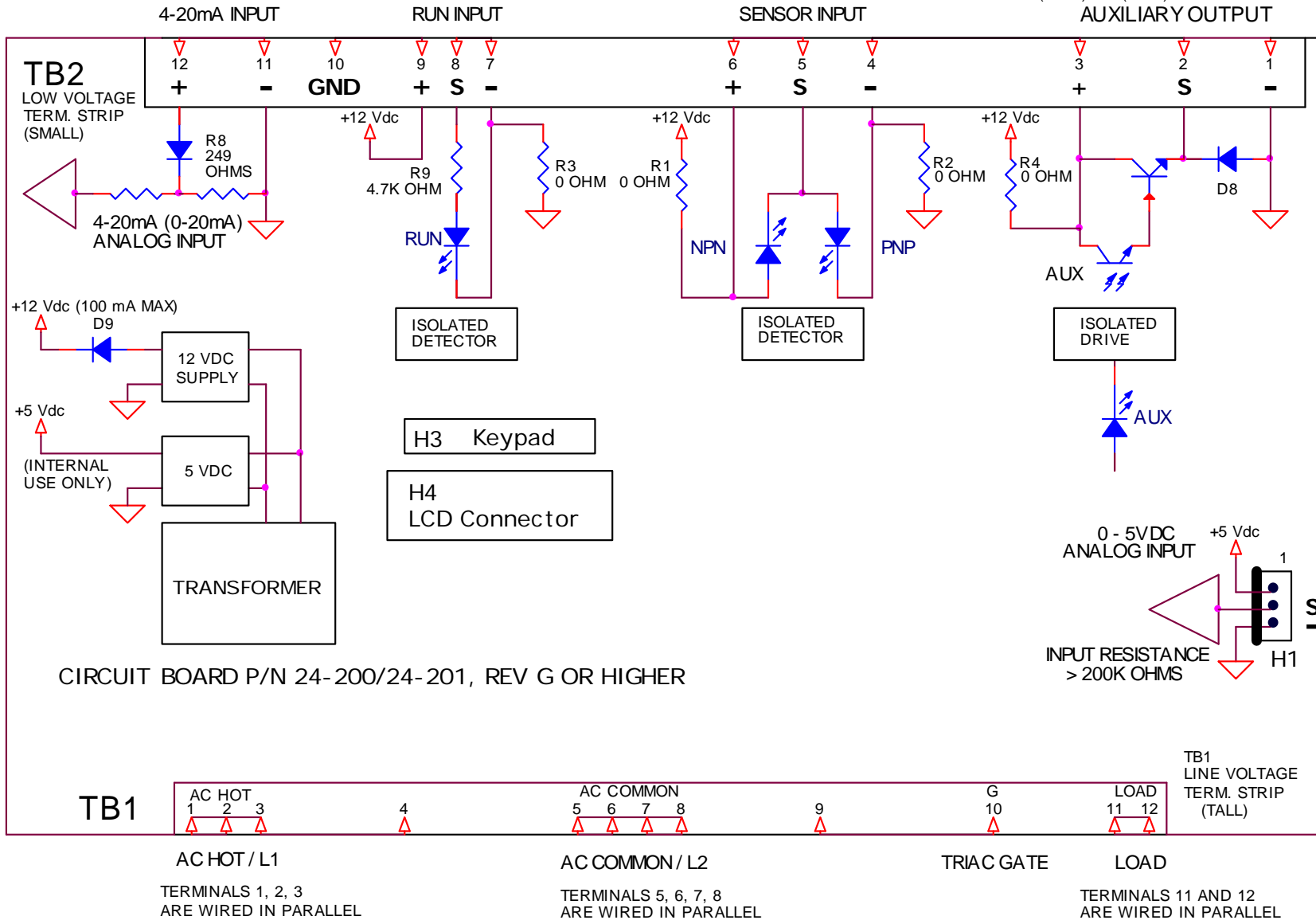

CIRCUIT BOARD P/N 24-200/24-201, REV G OR HIGHER

# FC-200 INTERFACE DIAGRAM

FC-200 PLUS SERIES EQUIVALENT CIRCUIT  
COPYRIGHT 2008, 2017 RODIX INC.

ATTENTION: AUXILIARY OUTPUT CONNECTIONS HAVE CHANGED FROM PREVIOUS MODELS.

THIS DIAGRAM IS FOR REFERENCE ONLY, SEE FC-200 SERIES  
APPLICATION NOTE FOR INTERCONNECT WIRING.